

NOTES:

1. FOR GRAVITY APPLICATIONS ONLY.
2. ALL PROCEPTOR UNITS ARE MANUFACTURED WITH FIBERGLASS REINFORCED PLASTICS.
PHYSICAL CHARACTERISTICS AND THICKNESS:
POLYESTER RESIN AND E GLASS
MINIMUM THICKNESS 1/4" WALL AND 3/8" TOP AND BOTTOM BOWLS.
3. ALL PROCEPTOR UNITS ARE TO BE INSTALLED IN ACCORDANCE WITH THE MANUFACTURERS INSTALLATION INSTRUCTION.
4. STANDARD PIPING IS SCH. 40 PVC.
5. GMC/OMC 500 - 3000 UNITS COME STANDARD WITH 4" INLET AND OUTLET (OTHER PIPE SIZE OPTIONS AVAILABLE ON REQUEST).
6. EXTENSION COLLAR TO BE ORDERED TO MEET FINISHED GRADE, CUT ON SITE FOR FINAL ADJUSTMENT AND CAULKED WITH SIKAFLEX BY CONTRACTOR FOR WATERTIGHT SEAL.
7. COVERS AVAILABLE FOR H20 TRAFFIC LOADING, PEDESTRIAN LOADING OR ABOVE GROUND INSTALLATION.
8. CONSULT GREEN TURTLE FOR OTHER SIZES.
9. 30 YEAR WARRANTY AGAINST LEAKS, AND STRUCTURAL FAILURE.
10. U.S. PATENT #5,746,912; CDN PATENT #2,195,822

US PAT. # 5746912



MANUFACTURER: GREEN TURTLE TECHNOLOGIES

PROCEPTOR MODEL NUMBER: GMC 1300-P UPC
LIQUID CAPACITY (WORKING VOLUME): 1300 US GAL.
RATED FLOW: STD. MAX BURIAL DEPTH TO TOP OF TANK: 6 FT.
MAX VERTICAL LOAD: 1133 PSF
MONTH/YEAR OF MANUFACTURE:

DETAIL A

TWO GMC 1000-P UPC IN SERIES

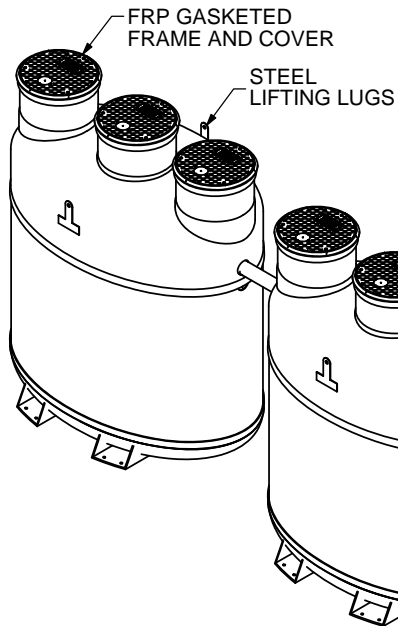

FOR UPC/IAPMO INSTALLATIONS
APPROVED UNDER PS 80-2008
MEETS ASTM C-581

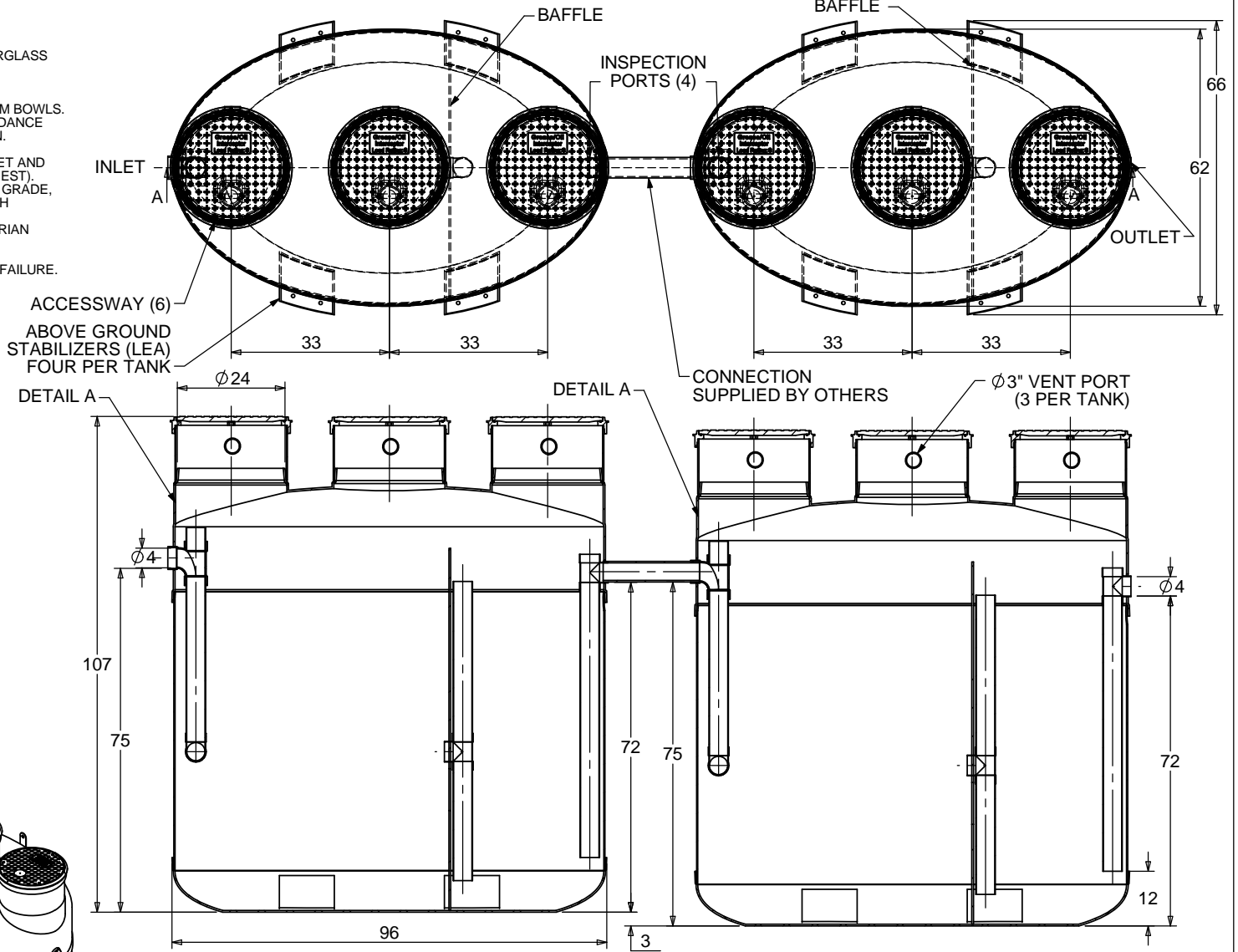

SECTION A-A SCALE 1 : 35 FOR UPC/IAPMO INSTALLATIONS

TITLE: PROCEPTOR SEPARATOR GMC 2600(2)-P UPC GALLON INTERCEPTOR 4" INLET & OUTLET 24" TRIPLE ACCESSWAY		REV	DATE	DRAWN
PROJECT: WO:		1		
AVAILABLE OPTIONS (CHECKED IF REQUESTED)		2		
<input type="checkbox"/>	OIL/GREASE SENSOR ALARM	3		
<input type="checkbox"/>	SUCTION PIPE FOR INDOOR INSTALLATION	4		
<input checked="" type="checkbox"/>	ABOVE GROUND CONFIGURATION	5		
<input type="checkbox"/>	DOUBLE WALL CONSTRUCTION	6		
<input type="checkbox"/>	OIL DRAW OFF PIPE TO CONNECT TO EXTERNAL OIL HOLDING TANK(FOR OIL ONLY)	7		
DRAWN BY: L. SIMKINS		8		
DATE DRAWN: 2018/08/08		9		
		10		



SIZE	DWG. NO.	REV.
A	GMC 2600(2)-P UPC	0
SCALE:1:35	DO NOT SCALE DRAWING	SHEET 1 OF 1