

**NOTES:**

1. FOR GRAVITY APPLICATIONS ONLY.
2. ALL PROCEPTOR UNITS ARE MANUFACTURED WITH FIBERGLASS REINFORCED PLASTICS; PHYSICAL CHARACTERISTICS: ISOPHTHALIC POLYESTER RESIN WITH E GLASS.
3. ALL PROCEPTOR UNITS ARE TO BE INSTALLED IN ACCORDANCE WITH THE MANUFACTURERS INSTALLATION INSTRUCTION.
4. STANDARD PIPING IS SCH. 40 PVC.
5. GMC/OMC 4,000 - 10,000 UNITS COME STANDARD WITH 6" INLET AND OUTLET (OTHER CUSTOM SIZES AVAILABLE AT EXTRA CHARGE).
6. ADVISE GREEN TURTLE OF INVERT DEPTH; DEEP INSTALLATIONS MAY REQUIRE CUSTOM REINFORCEMENT.
7. EXTENSION COLLAR TO BE ORDERED TO MEET FINISHED GRADE, CUT ON SITE FOR FINAL ADJUSTMENT, AND CAULKED WITH SIKAFLEX BY CONTRACTOR FOR WATERTIGHT SEAL.
8. COVERS AVAILABLE FOR H2O TRAFFIC LOADING, PEDESTRIAN LOADING OR ABOVE GROUND INSTALLATION.
9. CONSULT GREEN TURTLE FOR OTHER SIZES.
10. 30 YEAR WARRANTY AGAINST LEAKS, AND STRUCTURAL FAILURE.
11. U.S. PATENT #5,746,912; CDN PATENT #2,195,822

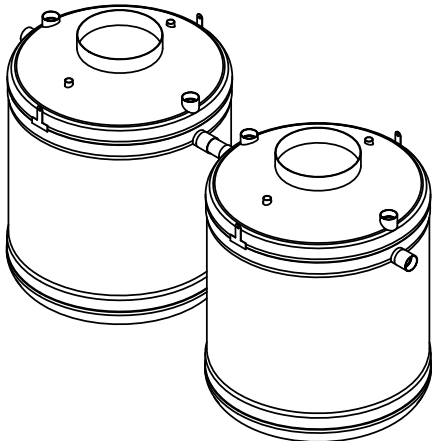
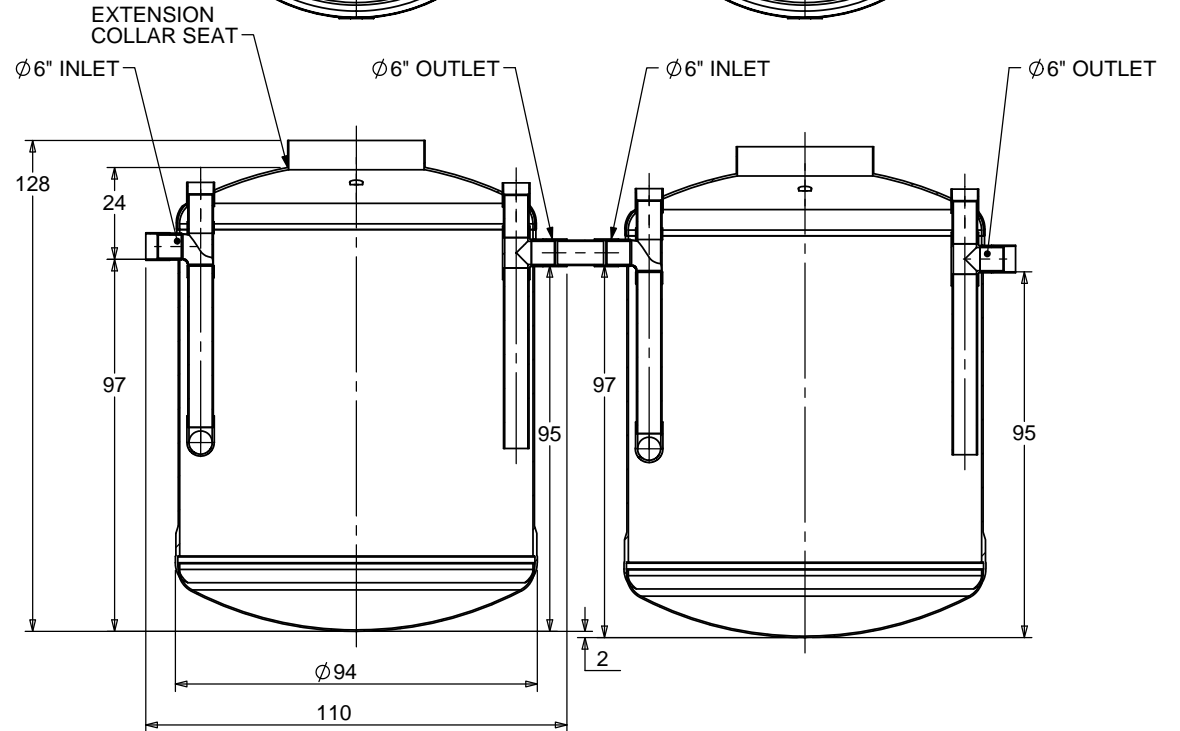
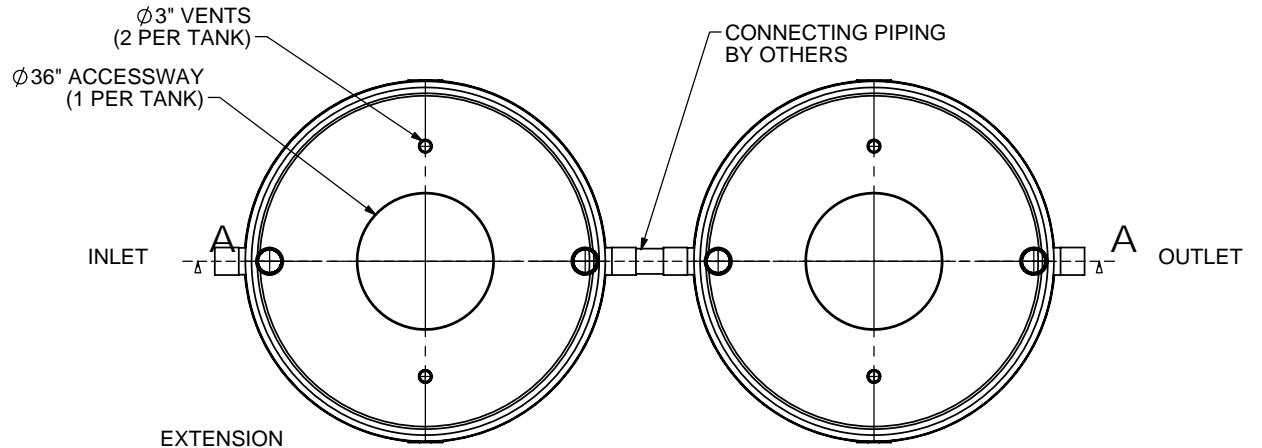

SECTION A-A

TOTAL WET VOLUME: 5000 GAL  
 MAX. OIL CAPACITY: 2226 GAL  
 MAX SOLIDS CAPACITY: 1776 GAL

CONSULT LOCAL AUTHORITIES FOR MINIMUM SIZE OF SEPARATORS

TITLE: PROCEPTOR SEPARATOR		REV	DATE	DRAWN
OMC 5000(2) GALLON INTERCEPTOR		1	NOVEMBER 12, 2007	L. SIMKINS
6" INLET & OUTLET		2	NOVEMBER 12, 2009	L. SIMKINS
36" ACCESSWAY		3	MARCH 29, 2012	L. SIMKINS
ALL DIMENSIONS IN INCHES		4	SEPT. 10, 2014	
PROJECT: WO:		5	SEPT. 29, 2015	
		6		
		7		
AVAILABLE OPTIONS (CHECKED IF REQUESTED)		8		
<input type="checkbox"/> OIL OR GREASE SENSOR ALARM		9		
<input type="checkbox"/> SUCTION PIPE FOR INDOOR INSTALLATION		10		
<input type="checkbox"/> ABOVE GROUND INSTALLATION				
		DRAWN BY: L. SIMKINS		SIZE
		DRAWN DATE: FEBRUARY 9, 2007		DWG. NO.

**Proceptor**<sup>®</sup>  
 by greenturtle<sup>®</sup>  
 US 877 428 8187 CAN 877 966 9444  
 www.greenturtletech.com

SIZE	DWG. NO.	REV.
<b>A</b>	OMC 5000(2)	<b>5</b>
SCALE: 1:50	DO NOT SCALE DRAWING	SHEET 1 OF 1