

**NOTES:**

1. FOR GRAVITY APPLICATIONS ONLY.
2. ALL PROCEPTOR UNITS ARE MANUFACTURED WITH FIBERGLASS REINFORCED PLASTICS.  
PHYSICAL CHARACTERISTICS AND THICKNESS:  
POLYESTER RESIN AND E GLASS  
MINIMUM THICKNESS 1/4" WALL AND 3/8" TOP AND BOTTOM BOWLS.
3. ALL PROCEPTOR UNITS ARE TO BE INSTALLED IN ACCORDANCE WITH THE MANUFACTURERS INSTALLATION INSTRUCTION.
4. STANDARD PIPING IS SCH. 40 PVC.
5. GMC/OMC 500 - 3000 UNITS COME STANDARD WITH 4" INLET AND OUTLET (OTHER PIPE SIZE OPTIONS AVAILABLE ON REQUEST).
6. EXTENSION COLLAR TO BE ORDERED TO MEET FINISHED GRADE, CUT ON SITE FOR FINAL ADJUSTMENT AND CAULKED WITH SIKAFLEX BY CONTRACTOR FOR WATERTIGHT SEAL.
7. COVERS AVAILABLE FOR H20 TRAFFIC LOADING, PEDESTRIAN LOADING OR ABOVE GROUND INSTALLATION.
8. CONSULT GREEN TURTLE FOR OTHER SIZES.
9. 30 YEAR WARRANTY AGAINST LEAKS, AND STRUCTURAL FAILURE.
10. U.S. PATENT #5,746,912; CDN PATENT #2,195,822

US PAT. # 5746912

**Proceptor**® 

MANUFACTURER: ZURN GREEN TURTLE

PROCEPTOR MODEL NUMBER: GMC 1000-P UPC  
LIQUID CAPACITY (WORKING VOLUME): 1000 US GAL  
RATED FLOW: 1000 US GAL  
STD. MAX BURIAL DEPTH TO TOP OF TANK: 6 FT.  
MAX VERTICAL LOAD: 1133 PSF  
MONTH/YEAR OF MANUFACTURE:

DETAIL "A"

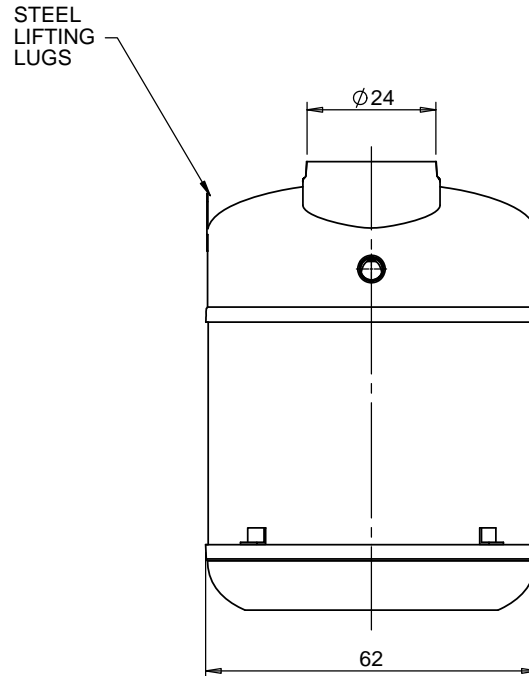
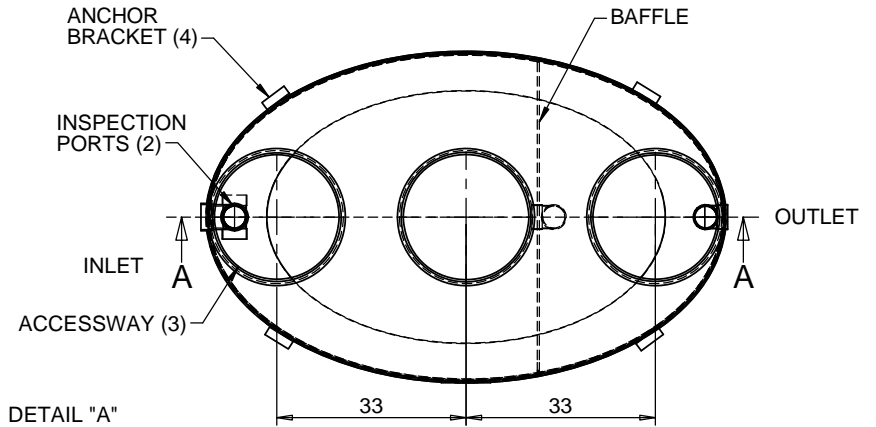

FOR UPC/IAPMO INSTALLATIONS

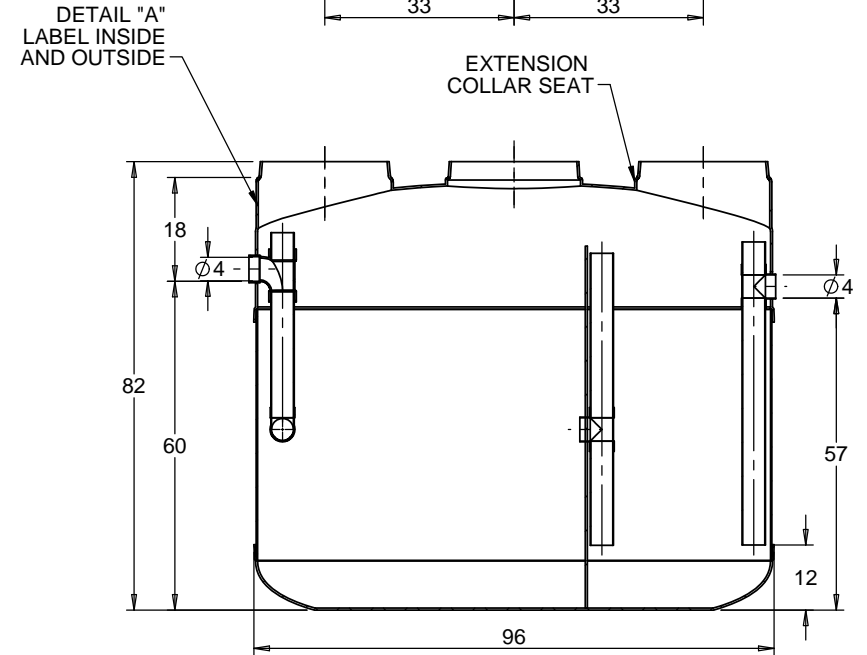

SECTION A-A  
SCALE 1 : 35

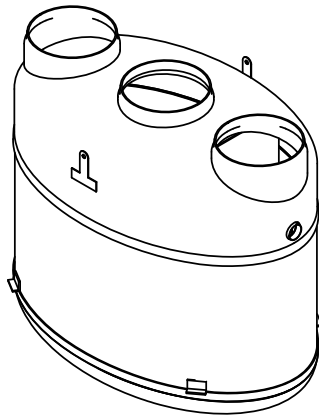

FOR UPC/IAPMO INSTALLATIONS  
APPROVED UNDER PS 80-2008  
MEETS ASTM C-581

TITLE: PROCEPTOR SEPARATOR GMC 1000-P UPC GALLON INTERCEPTOR 4" INLET & OUTLET 24" TRIPLE ACCESSWAY		REV	DATE	DRAWN
PROJECT: WO:		1		
AVAILABLE OPTIONS (CHECKED IF REQUESTED)		2		
<input type="checkbox"/> OIL/GREASE SENSOR ALARM		3		
<input type="checkbox"/> SUCTION PIPE FOR INDOOR INSTALLATION		4		
<input type="checkbox"/> ABOVE GROUND CONFIGURATION		5		
<input type="checkbox"/> DOUBLE WALL CONSTRUCTION		6		
<input type="checkbox"/> OIL DRAW OFF PIPE TO CONNECT TO EXTERNAL OIL HOLDING TANK (FOR OIL ONLY)		7		
		8		
		9		
		10		
DRAWN BY: L. SIMKINS				
DATE DRAWN: 2018/08/08				



SIZE	DWG. NO.	REV.
A	GMC 1000-P UPC	0
SCALE: 1:35	DO NOT SCALE DRAWING	SHEET 1 OF 1