

NOTES:

1. FOR GRAVITY APPLICATIONS ONLY.
2. ALL PROCEPTOR UNITS ARE MANUFACTURED WITH FIBERGLASS REINFORCED PLASTICS.
3. ALL PROCEPTOR UNITS ARE TO BE INSTALLED IN ACCORDANCE WITH THE MANUFACTURER'S INSTALLATION INSTRUCTION.
4. STANDARD PIPING IS SCH. 40 PVC.
5. GMC/OMC 500 - 3000 UNITS COME STANDARD WITH 4" INLET AND OUTLET (OTHER PIPE SIZE OPTIONS AVAILABLE ON REQUEST).
6. EXTENSION COLLAR TO BE ORDERED TO MEET FINISHED GRADE, CUT ON SITE FOR FINAL ADJUSTMENT AND CAULKED WITH SIKAFLEX BY CONTRACTOR FOR WATERTIGHT SEAL.
7. COVERS AVAILABLE FOR H2O TRAFFIC LOADING, PEDESTRIAN LOADING OR ABOVE GROUND INSTALLATION.
8. CONSULT GREEN TURTLE FOR OTHER SIZES.
9. 30 YEAR WARRANTY AGAINST LEAKS, AND STRUCTURAL FAILURE.
10. U.S. PATENT #5,746,912; CDN PATENT #2,195,822

US PAT. # 5746912

Proceptor®



MANUFACTURER: ZURN GREEN TURTLE

PROCEPTOR MODEL NUMBER: GMC 750-P UPC
 LIQUID CAPACITY (WORKING VOLUME): 750 US GAL.
 RATED FLOW: 6 FT.
 STD. MAX BURIAL DEPTH TO TOP OF TANK: 1133 PSF
 MAX VERTICAL LOAD:
 MONTH/YEAR OF MANUFACTURE:

DETAIL "A"

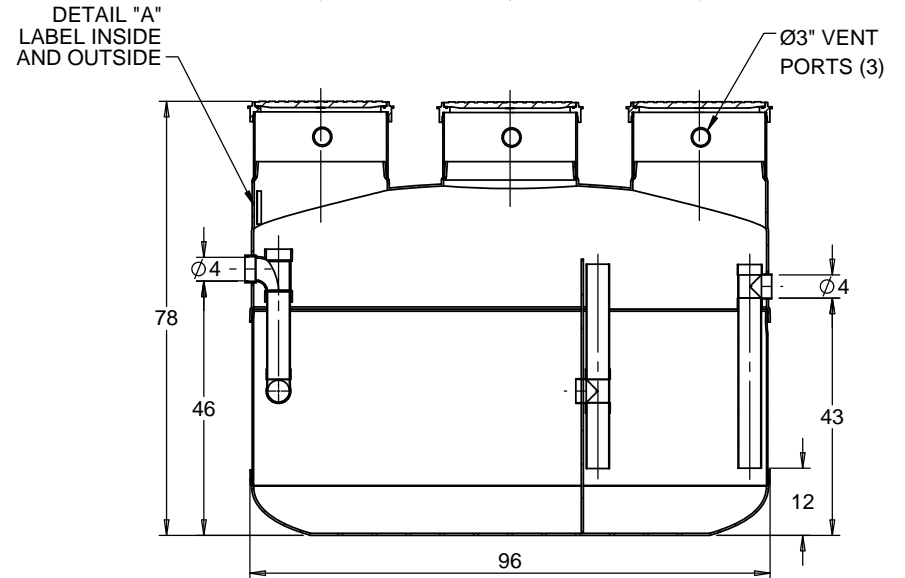
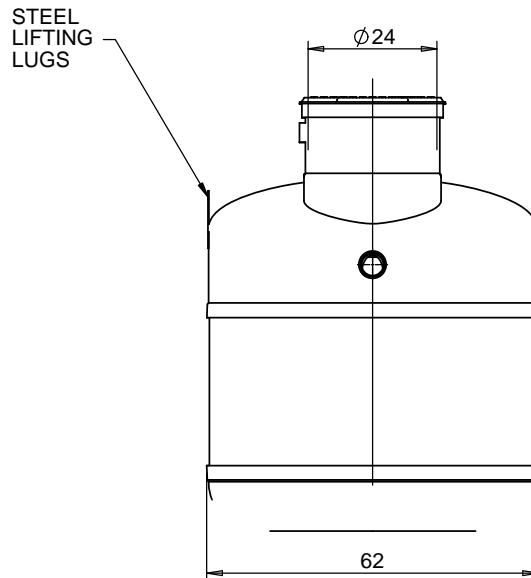
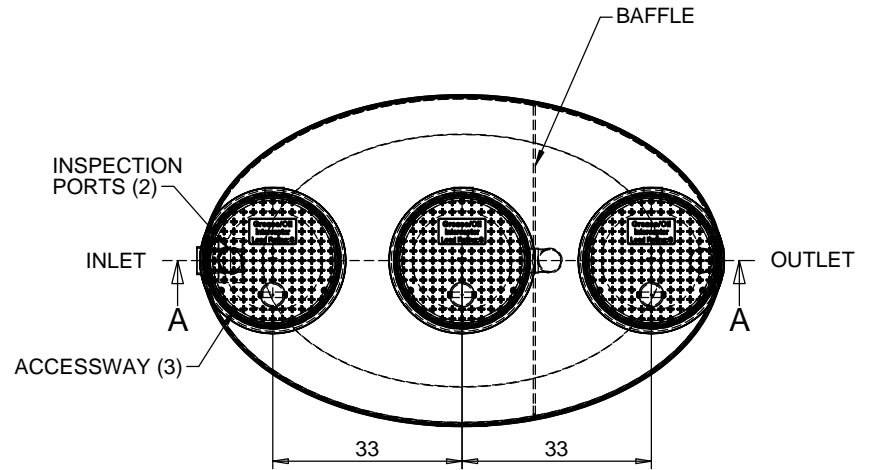

SECTION A-A
SCALE 1 : 35

FOR UPC/IAPMO INSTALLATIONS

**FOR UPC/IAPMO INSTALLATIONS
APPROVED UNDER PS 80-2008
MEETS ASTM C-581**

TITLE: PROCEPTOR SEPARATOR GMC 750-P UPC GALLON INTERCEPTOR 4" INLET & OUTLET 24" TRIPLE ACCESSWAY	REV	DATE	DRAWN
PROJECT: WO:	1		
	2		
	3		
	4		
	5		
	6		
AVAILABLE OPTIONS (CHECKED IF REQUESTED)	7		
<input type="checkbox"/> OIL/GREASE SENSOR ALARM	8		
<input type="checkbox"/> SUCTION PIPE FOR INDOOR INSTALLATION	9		
<input checked="" type="checkbox"/> ABOVE GROUND CONFIGURATION	10		
<input type="checkbox"/> DOUBLE WALL CONSTRUCTION			
<input type="checkbox"/> OIL DRAW OFF PIPE TO CONNECT TO EXTERNAL OIL HOLDING TANK(FOR OIL ONLY)			
	DRAWN BY: L. SIMKINS		
	DATE DRAWN: 2018/08/08		



SIZE	DWG. NO.	REV.
A	GMC 750-P UPC	0
SCALE:1:35	DO NOT SCALE DRAWING	SHEET 1 OF 1