

**NOTES:**

1. FOR GRAVITY APPLICATIONS ONLY.
2. ALL PROCEPTOR UNITS ARE MANUFACTURED WITH FIBERGLASS REINFORCED PLASTICS. PHYSICAL CHARACTERISTICS AND THICKNESS: POLYESTER RESIN AND E GLASS MINIMUM THICKNESS 1/4" WALL AND 3/8" TOP AND BOTTOM BOWLS.
3. ALL PROCEPTOR UNITS ARE TO BE INSTALLED IN ACCORDANCE WITH THE MANUFACTURERS INSTALLATION INSTRUCTION.
4. STANDARD PIPING IS SCH. 40 PVC.
5. GMC/OMC 500 - 3000 UNITS COME STANDARD WITH 4" INLET AND OUTLET (OTHER PIPE SIZE OPTIONS AVAILABLE ON REQUEST).
6. EXTENSION COLLAR TO BE ORDERED TO MEET FINISHED GRADE, CUT ON SITE FOR FINAL ADJUSTMENT AND CAULKED WITH SIKAFLEX BY CONTRACTOR FOR WATERTIGHT SEAL.
7. COVERS AVAILABLE FOR H2O TRAFFIC LOADING, PEDESTRIAN LOADING OR ABOVE GROUND INSTALLATION.
8. CONSULT GREEN TURTLE FOR OTHER SIZES.
9. 30 YEAR WARRANTY AGAINST LEAKS, AND STRUCTURAL FAILURE.
10. U.S. PATENT #5,746,912; CDN PATENT #2,195,822

**SPECIFICATIONS**

PIPE SIZE: 4 INCH PVC SCH 40  
 INSTALLATION: BURIED  
 ACCESSWAY SIZE: 24 INCHES

**OPTIONS**

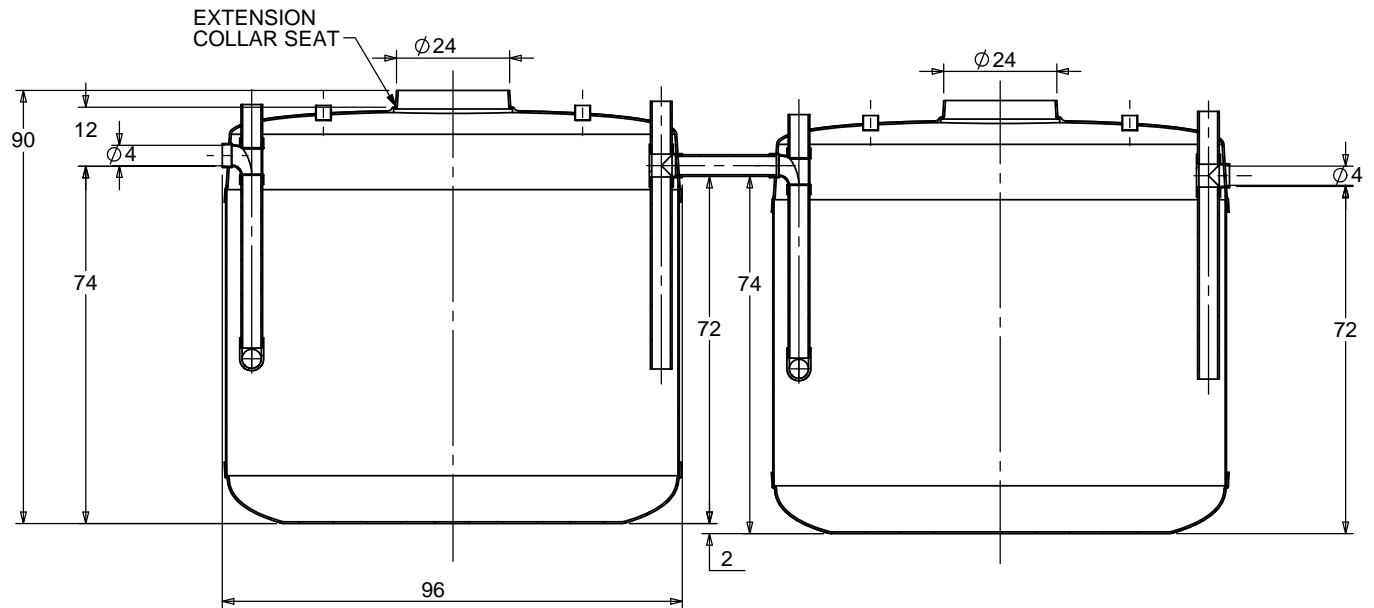
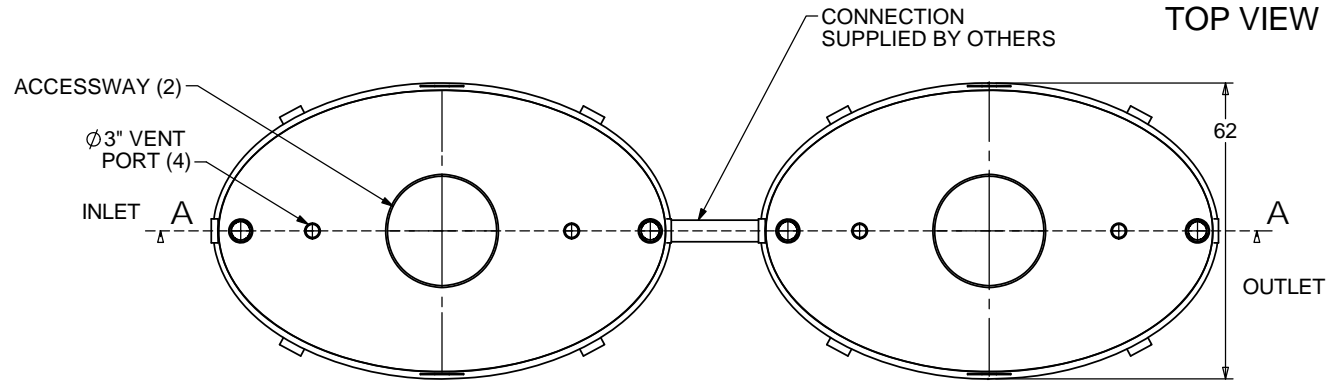

SECTION A-A

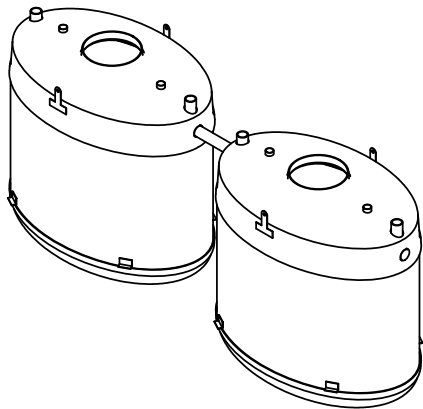

TOTAL WET VOLUME: 2600 GAL  
 MAX. GREASE CAPACITY: 1415 GAL  
 MAX SOLIDS CAPACITY: 891 GAL

CONSULT LOCAL AUTHORITIES FOR MINIMUM SIZE OF SEPARATORS

TITLE: PROCEPTOR® F.O.G. SEPARATOR  
 GMC 2600(2)

PROJECT: WO:

NOTES:

REV	DATE	DRAWN
1		
2		
3	JUNE 15, 2005	L. SIMKINS
4	JANUARY 4, 2007	L. SIMKINS
5	NOVEMBER 10, 2009	L. SIMKINS
6	MARCH 1, 2012	L. SIMKINS
7	SEPT. 08, 2014	
8	APRIL 27, 2017	
9		
10		

DRAWN BY: F CHANDLER  
 DRAWN DATE 9/14/04



SIZE	DWG. NO.	REV.
A	GMC 2600(2)	8
SCALE:1:40	DO NOT SCALE DRAWING	SHEET 1 OF 1