

NOTES:

1. FOR GRAVITY APPLICATIONS ONLY.
2. ALL PROCEPTOR UNITS ARE MANUFACTURED WITH FIBERGLASS REINFORCED PLASTICS. PHYSICAL CHARACTERISTICS AND THICKNESS: POLYESTER RESIN AND E GLASS MINIMUM THICKNESS 1/4" WALL AND 3/8" TOP AND BOTTOM BOWLS.
3. ALL PROCEPTOR UNITS ARE TO BE INSTALLED IN ACCORDANCE WITH THE MANUFACTURERS INSTALLATION INSTRUCTION.
4. STANDARD PIPING IS SCH. 40 PVC.
5. GMC/OMC 500 - 3000 UNITS COME STANDARD WITH 4" INLET AND OUTLET (OTHER PIPE SIZE OPTIONS AVAILABLE ON REQUEST).
6. EXTENSION COLLAR TO BE ORDERED TO MEET FINISHED GRADE, CUT ON SITE FOR FINAL ADJUSTMENT AND CAULKED WITH SIKAFLEX BY CONTRACTOR FOR WATERTIGHT SEAL.
7. COVERS AVAILABLE FOR H2O TRAFFIC LOADING, PEDESTRIAN LOADING OR ABOVE GROUND INSTALLATION.
8. CONSULT GREEN TURTLE FOR OTHER SIZES.
9. 30 YEAR WARRANTY AGAINST LEAKS, AND STRUCTURAL FAILURE.
10. U.S. PATENT #5,746,912; CDN PATENT #2,195,822

US PAT. # 5746912

Proceptor[®]



MANUFACTURER: GREEN TURTLE TECHNOLOGIES

PROCEPTOR MODEL NUMBER: GMC 750 UPC
 LIQUID CAPACITY (WORKING VOLUME): 750 US GAL.
 RATED FLOW:
 STD. MAX BURIAL DEPTH TO TOP OF TANK: 6 FT.
 MAX VERTICAL LOAD: 1133 PSF
 MONTH/YEAR OF MANUFACTURE:

DETAIL "A"

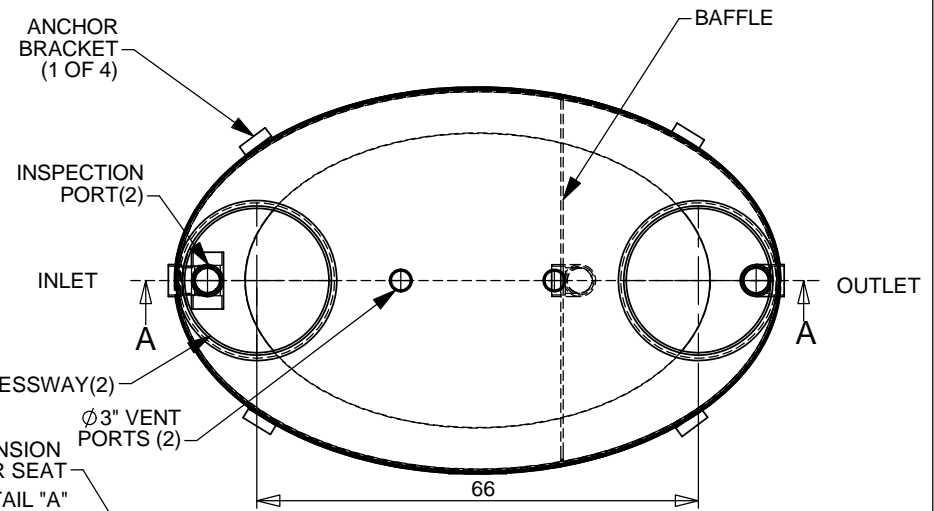

STEEL LIFTING LUGS

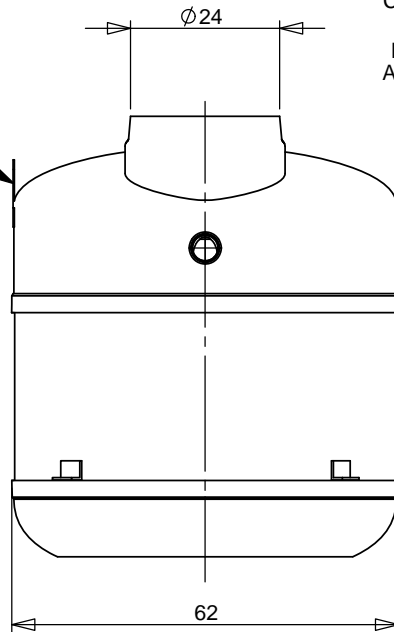

DETAIL "A"
 LABEL INSIDE
 AND OUTSIDE

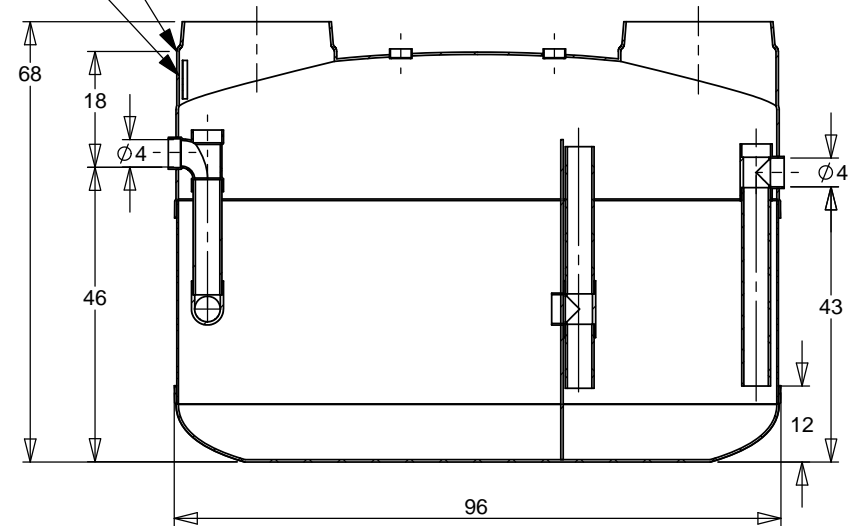

SECTION A-A
 SCALE 1 : 30

FOR UPC/IAPMO INSTALLATIONS

**FOR UPC/IAPMO INSTALLATIONS
 APPROVED UNDER IAPMO / ANSI Z1001-2007
 MEETS ASTM C-581**

TITLE: PROCEPTOR F.O.G. SEPARATOR GMC 750 UPC GALLON INTERCEPTOR 4" INLET & OUTLET 24" ACCESSWAY		REV	DATE	DRAWN
PROJECT: WO:		1	6/15/04	F. CHANDLER
AVAILABLE OPTIONS (CHECKED IF REQUESTED)		2	9/20/05	L. SIMKINS
<input type="checkbox"/> OIL/GREASE SENSOR ALARM		3	JANUARY 2, 2007	L. SIMKINS
<input type="checkbox"/> SUCTION PIPE FOR INDOOR INSTALLATION		4	MAY 12, 2008	L. SIMKINS
<input type="checkbox"/> DOUBLE WALL CONSTRUCTION		5	NOVEMBER 16, 2009	L. SIMKINS
<input type="checkbox"/> ABOVE GROUND CONFIGURATION		6	APRIL 3, 2012	L. SIMKINS
		7	OCTOBER 01, 2012	S. MANGAT
		8	FEBRUARY 11, 2013	S. MANGAT
		9	NOV. 11, 2014	
		10		
DRAWN BY: F. CHANDLER		DATE DRAWN: 6/15/04		

Proceptor[®]
 by greenturtle[®]
 US 877 428 8187 CAN 877 966 9444
 www.greenturtletech.com

SIZE	DWG. NO.	REV.
A	GMC 750 UPC	9
SCALE:1:30	DO NOT SCALE DRAWING	SHEET 1 OF 1