

NOTES:

1. FOR GRAVITY APPLICATIONS ONLY.
2. ALL PROCEPTOR UNITS ARE MANUFACTURED WITH FIBERGLASS REINFORCED PLASTICS; PHYSICAL CHARACTERISTICS:
ISOPHTHALIC POLYESTER RESIN WITH E GLASS.
3. ALL PROCEPTOR UNITS ARE TO BE INSTALLED IN ACCORDANCE WITH THE MANUFACTURERS INSTALLATION INSTRUCTION.
4. STANDARD PIPING IS SCH. 40 PVC.
5. GMC/OMC 4,000 - 10,000 UNITS COME STANDARD WITH 6" INLET AND OUTLET (OTHER PIPE SIZE OPTIONS AVAILABLE ON REQUEST).
6. ADVISE GREEN TURTLE OF INVERT DEPTH; DEEP INSTALLATIONS MAY REQUIRE CUSTOM REINFORCEMENT.
7. EXTENSION COLLAR TO BE ORDERED TO MEET FINISHED GRADE.
8. CUT ON SITE FOR FINAL ADJUSTMENT, AND CAULKED WITH SIKAFLEX BY CONTRACTOR FOR WATERTIGHT SEAL.
9. SIKAFLEX BY CONTRACTOR FOR WATERTIGHT SEAL.
10. 30 YEAR WARRANTY AGAINST LEAKS, AND STRUCTURAL FAILURE.
11. U.S. PATENT #5,746,912; CDN PATENT #2,195,822

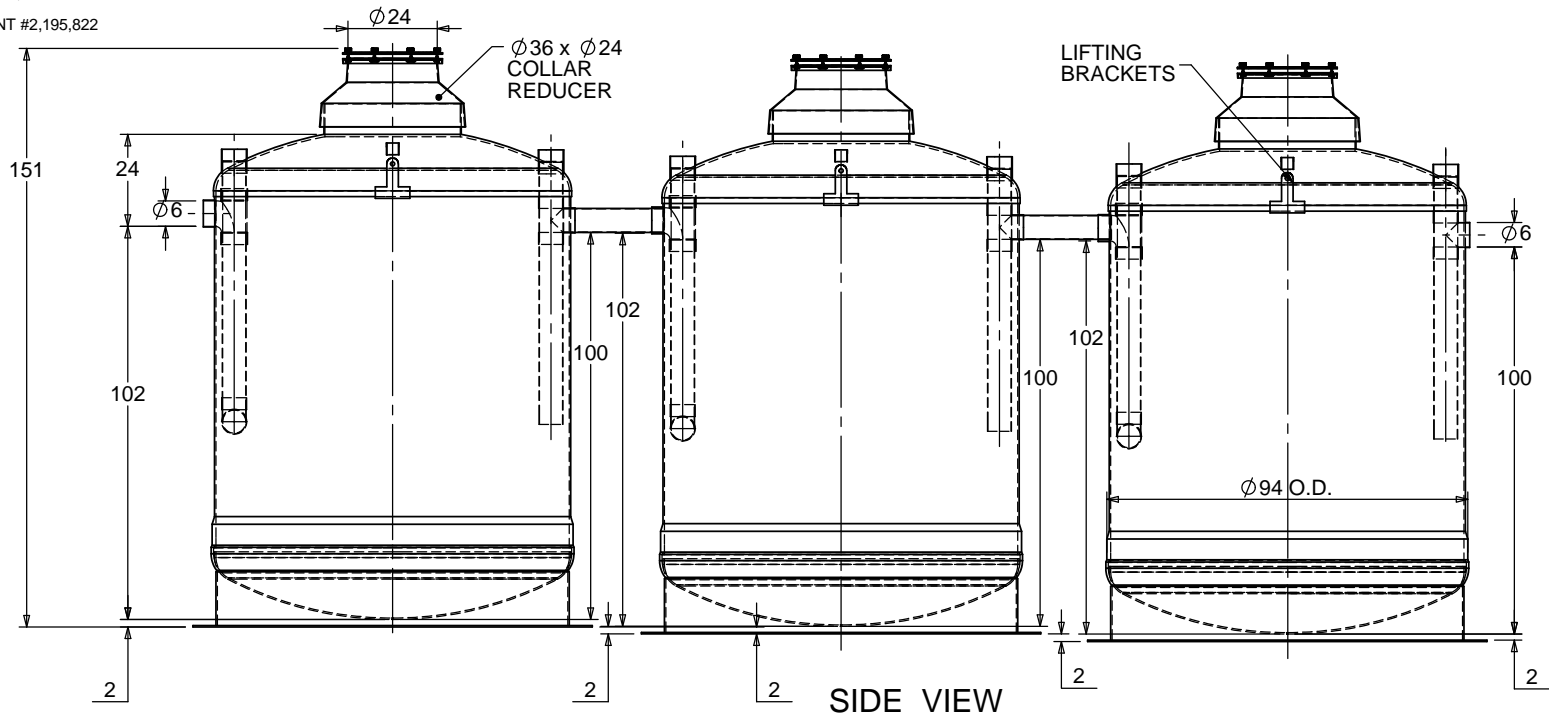
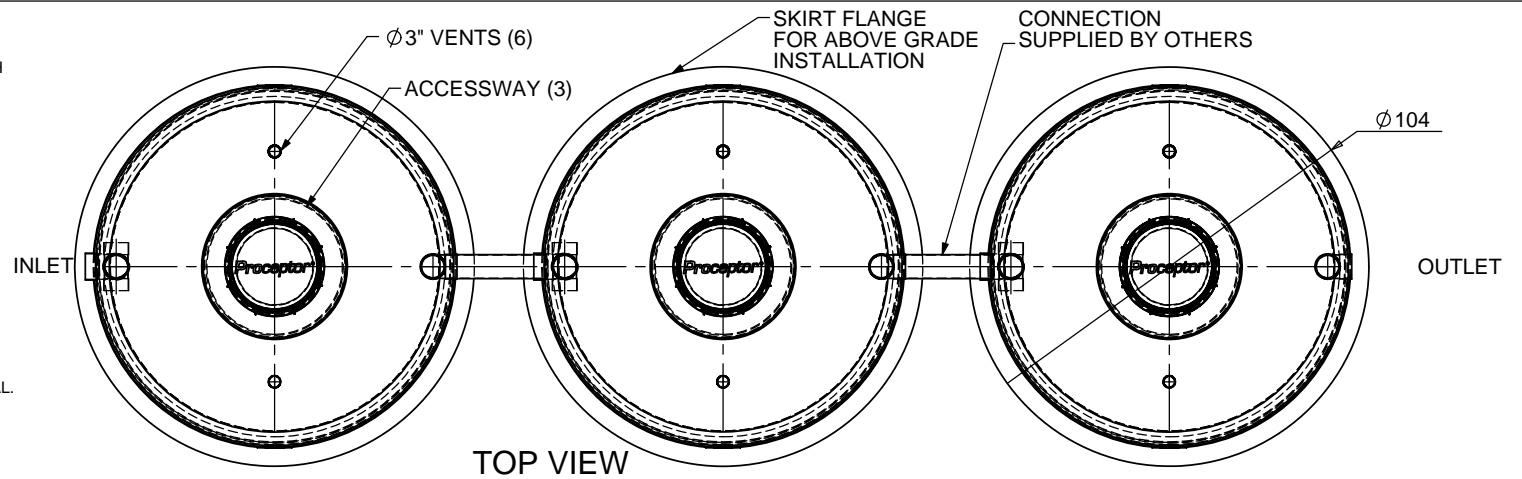

TOTAL WET VOLUME: 8000 GAL
 MAX. OIL CAPACITY: 3810 GAL
 MAX SOLIDS CAPACITY: 2707 GAL

CONSULT LOCAL AUTHORITIES FOR MINIMUM SIZE OF SEPARATORS

TITLE: PROCEPTOR
 OMC 8000 GALLON INTERCEPTOR
 6" INLET & OUTLET
 24" ACCESSWAY
 ALL DIMENSIONS IN INCHES

PROJECT: WO:

AVAILABLE OPTIONS (CHECKED IF REQUESTED)	
<input type="checkbox"/>	OIL OR GREASE SENSOR ALARM
<input type="checkbox"/>	SUCTION PIPE FOR INDOOR INSTALLATION
<input checked="" type="checkbox"/>	ABOVE GROUND INSTALLATION

REV	DATE	DRAWN
1	JANUARY 7, 2008	L. SIMKINS
2	NOVEMBER 13, 2009	L. SIMKINS
3		
4	MARCH 29, 2012	L. SIMKINS
5		
6		
7		
8		
9		
10		

DRAWN BY: L. SIMKINS
 DRAWN DATE: FEBRUARY 9, 2007

Proceptor®
 by greenturtle®
 US 877 428 8187 CAN 877 966 9444
 www.greenturtletech.com

SIZE	DWG. NO.	REV.
A	OMC 8000(3)	4

SCALE: 1:50 DO NOT SCALE DRAWING SHEET 1 OF 1