

GMC 500-2000 DUAL MANWAY (UPC, FLORIDA) ABOVE GROUND INSTALLATION

NOTES:

1. ENSURE FLOOR IS LEVEL, SMOOTH, AND IS ABLE TO SUPPORT THE WEIGHT OF THE TANKS FULL OF WATER AT INSTALLATION LOCATION.
2. MOVE TANKS INTO POSITION. CHECK FIT AND LOCATION OF INLET, OUTLET AND VENT PIPING (WHERE APPLICABLE).
3. ENSURE ACCESSWAY IS ACCESSIBLE FOR COVER REMOVAL AND PUMPOUT AS WELL AS ACCESS TO THE INTERIOR. ENSURE ALL OTHER PORTS ARE ACCESSIBLE FOR INSTALLATION AND MAINTENANCE.
ALARM PROBES (IF SUPPLIED) SHOULD HAVE SUFFICIENT HEADSPACE FOR REMOVAL TO CALIBRATE OR SERVICE.
4. ENSURE AREA AROUND TANK IS HEATED TO PREVENT FREEZING OF WATER IN TANK AND PIPES.
5. THE STABILIZATION SUPPORTS MAY BE AFFIXED TO FLOOR IF DESIRED.
6. SEISMIC RESTRAINTS TO BE PROVIDED BY OTHERS IF REQUIRED BY LOCAL AUTHORITIES
7. INSTALL INLET, OUTLET AND VENT PIPES TO MEET LOCAL PLUMBING CODE.
8. PRIOR TO COMMENCING OPERATIONS, FILL TANK WITH CLEAN WATER.
9. US PATENT # 5,746,912; CDN PATENT # 2,195,822
10. PROCEPTOR SEPARATORS MUST BE INSTALLED IN ACCORDANCE WITH ALL RELEVANT FEDERAL, PROVINCIAL, STATE, AND LOCAL CODES INCLUDING LOCAL PLUMBING CODE.

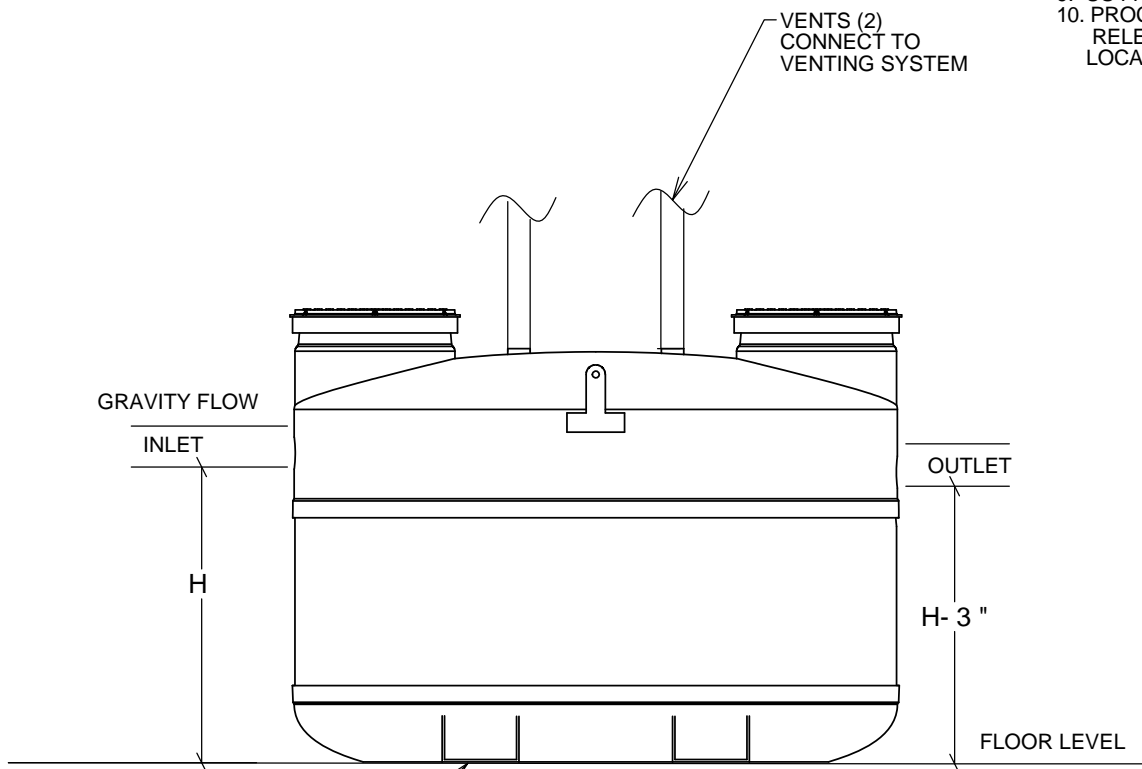

| PROCEPTOR F.O.G. SEPARATOR MODEL | INLET INVERT TO TANK BOTTOM (H) | WEIGHT OF TANK FULL OF WATER (lbs) |
|----------------------------------|---------------------------------|------------------------------------|
| GMC 500 UPC | 33" | 4740 |
| GMC 750 UPC | 46" | 6935 |
| GMC 1000 UPC | 60" | 9100 |
| GMC 1300 UPC | 75" | 11700 |
| GMC 1500 UPC | 86" | 13430 |
| GMC 750 FL | 46" | 6935 |
| GMC 1000 FL | 60" | 9100 |
| GMC 1250 FL | 75" | 11700 |
| GMC 1500 FL | 86" | 13430 |
| GMC 2000 UPC | 110" | 17721 |

ABOVE GROUND STABILIZERS
(REQUIRED ON
MODELS 750 AND LARGER)

TITLE: PROCEPTOR F.O.G. SEPARATOR
INSTALLATION PROCEDURE
ABOVE GROUND DUAL MANWAY
ALL DIMENSIONS IN INCHES

PROJECT: _____ WO: _____

| REV | DATE | DRAWN |
|-----|------------------|------------|
| 1 | MARCH 16, 2006 | L. SIMKINS |
| 2 | NOV. 30, 2006 | L. SIMKINS |
| 3 | APRIL 14, 2008 | L. SIMKINS |
| 4 | JANUARY 16, 2009 | L. SIMKINS |
| 5 | AUGUST 14, 2009 | L. SIMKINS |
| 6 | JULY 23, 2013 | S. MANGAT |
| 7 | MAY 01, 2015 | S. MANGAT |
| 8 | MAY 27, 2016 | |
| 9 | MAY 25, 2017 | |
| 10 | | |

DRAWN BY: L. SIMKINS

DRAWN DATE: 03/14/06

Proceptor®

ZURN®

| | | |
|------------------|--|------------------|
| SIZE A | DWG. NO. Install GMC 500-2000 UPC FL ABOVE GROUND | REV. 9 |
| SCALE: 1:35 | DO NOT SCALE DRAWING | SHEET 1 OF 1 |