

NOTES:

1. FOR GRAVITY APPLICATIONS ONLY.
2. ALL PROCEPTOR UNITS ARE MANUFACTURED WITH FIBERGLASS REINFORCED PLASTICS. PHYSICAL CHARACTERISTICS AND THICKNESS: POLYESTER RESIN AND E GLASS MINIMUM THICKNESS 1/4" WALL AND 3/8" TOP AND BOTTOM BOWLS.
3. ALL PROCEPTOR UNITS ARE TO BE INSTALLED IN ACCORDANCE WITH THE MANUFACTURERS INSTALLATION INSTRUCTION.
4. STANDARD PIPING IS SCH. 40 PVC.
5. GMC/OMC 500 - 3000 UNITS COME STANDARD WITH 4" INLET AND OUTLET (OTHER PIPE SIZE OPTIONS AVAILABLE ON REQUEST).
6. EXTENSION COLLAR TO BE ORDERED TO MEET FINISHED GRADE, CUT ON SITE FOR FINAL ADJUSTMENT AND CAULKED WITH SIKAFLEX BY CONTRACTOR FOR WATERTIGHT SEAL.
7. COVERS AVAILABLE FOR H2O TRAFFIC LOADING, PEDESTRIAN LOADING OR ABOVE GROUND INSTALLATION.
8. CONSULT GREEN TURTLE FOR OTHER SIZES.
9. 30 YEAR WARRANTY AGAINST LEAKS, AND STRUCTURAL FAILURE.
10. U.S. PATENT #5,746,912; CDN PATENT #2,195,822

SPECIFICATIONS

PIPE SIZE: 4 INCH PVC SCH 40
 INSTALLATION: BURIED
 ACCESSWAY SIZE: 24 INCHES

OPTIONS

TOP VIEW

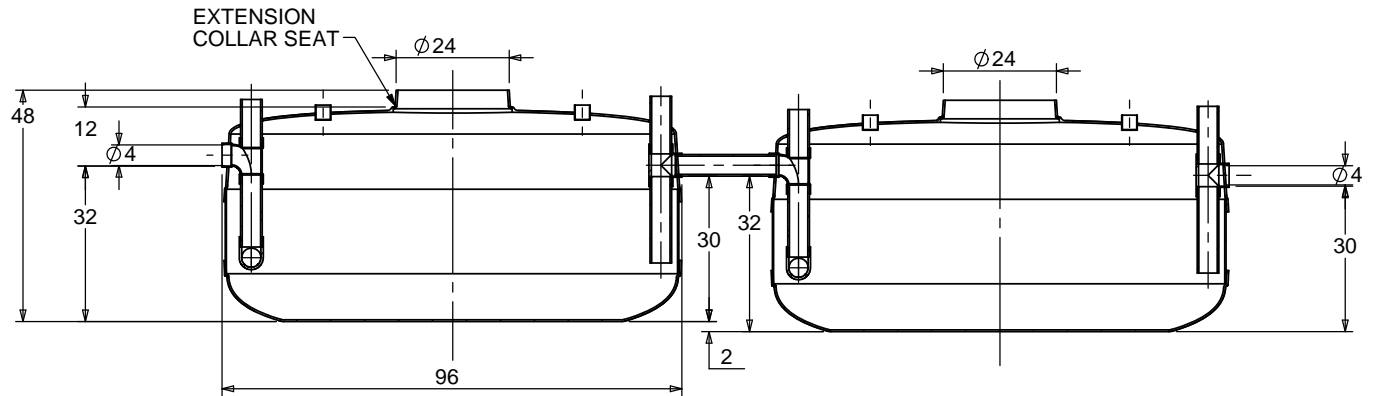
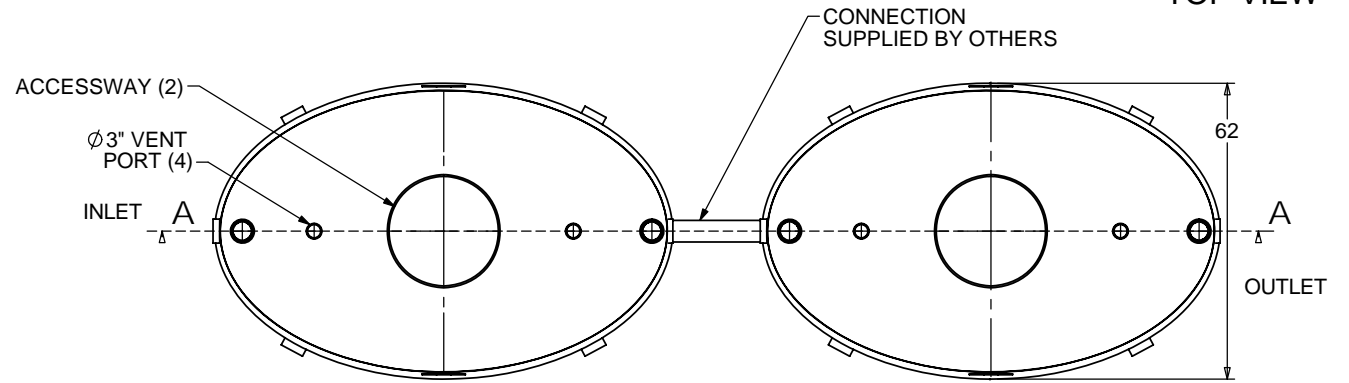

SECTION A-A

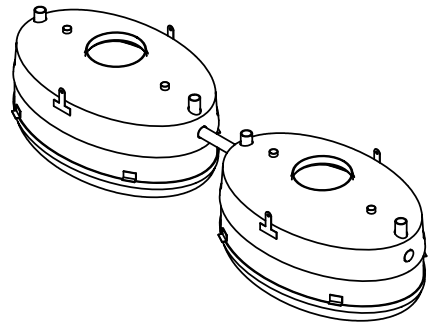

TOTAL WET VOLUME: 1000 GAL
 MAX. GREASE CAPACITY: 559 GAL
 MAX SOLIDS CAPACITY: 174 GAL

CONSULT LOCAL AUTHORITIES FOR MINIMUM SIZE OF SEPARATORS

TITLE: PROCEPTOR® F.O.G. SEPARATOR
 GMC 1000(2)

PROJECT: WO:

NOTES:

REV	DATE	DRAWN
1	JANUARY 4, 2007	L. SIMKINS
2	NOVEMBER 5, 2009	L. SIMKINS
3	APRIL 5, 2012	L. SIMKINS
4	APRIL 27, 2017	
5		
6		
7		
8		
9		
10		

DRAWN BY: L. SIMKINS
 DRAWN DATE: 8/26/5



SIZE	DWG. NO.	REV.
A	GMC 1000(2)	4
SCALE: 1:40		DO NOT SCALE DRAWING
		SHEET 1 OF 1