



PRE-RINSE UNIT

Z80000-PR1

TAG _____

Engineering Specification: Zurn AquaSpec® Z80000-PR1

Self-closing 1.6 GPM @ 60 psi (6.1 l/min @ 400 kPa) pre-rinse valve with an insulated 6" [152mm] handle, a stay open handle clip and protective bumper spray head. Unit has a 7/8-20 UNEF threaded male inlet. Complies with ASME A112.18.1/CSA B125.1. Certified to ASTM Standard Test Method F2324-03 for flow rate and cleanability.



Zurn Lead Compliant* "XL" products are a line of durable, high quality brass faucets and fixtures that are designed and manufactured to comply with state laws and local codes that mandate lead content levels. Zurn "XL" products are manufactured with *not more than 0.25% lead content when used with respect to wetted surfaces of pipes and pipe fittings, plumbing fitting and fixtures: California Health & Safety Code § 116875; Vermont 9 VCA § 2470h.

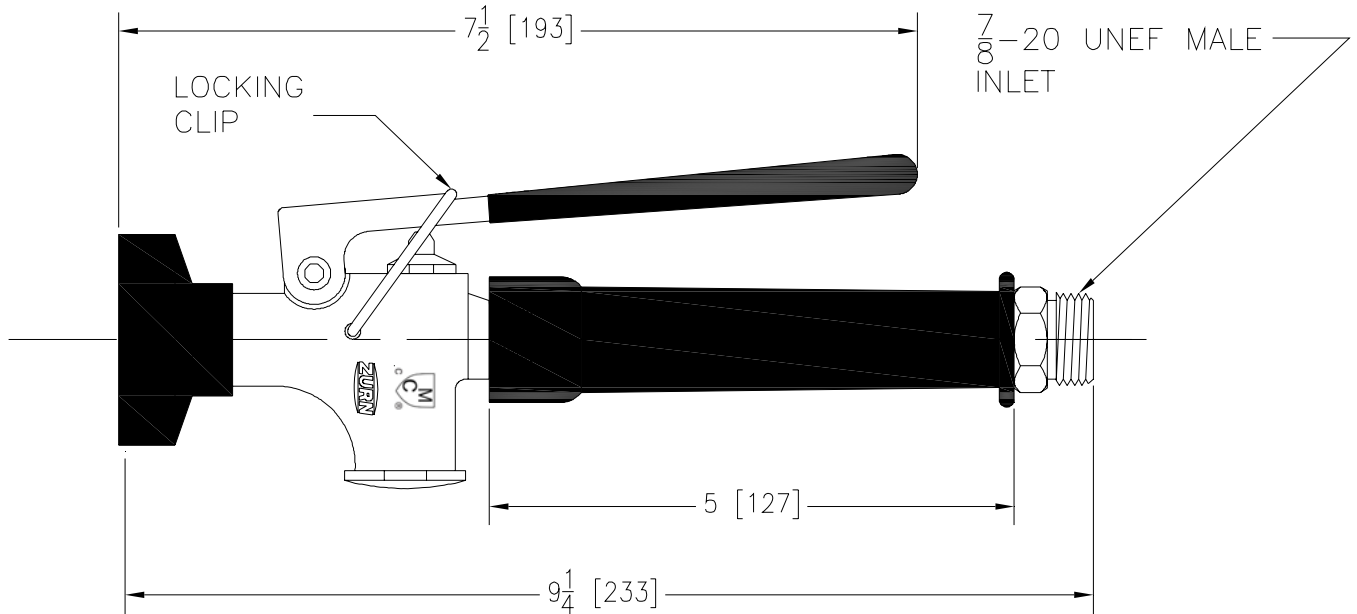

Note: All dimensions are for reference only. Do not use for pre-plumbing.

OPTIONAL ACCESSORIES

No options required.

ZURN INDUSTRIES, LLC ♦ COMMERCIAL BRASS OPERATION ♦ 2640 SOUTH WORK STREET ♦ FALCONER NY 14733

Phone: 1-800-997-3876 ♦ Fax: 1-919-775-3541 ♦ www.zurn.com

In Canada: ZURN INDUSTRIES LIMITED ♦ 3544 Nashua Drive ♦ Mississauga, Ontario L4V1L2 ♦ Phone: 905/405-8272 Fax: 905/405-1292