



KITCHEN SINK FAUCET

Z871G3-XL-HS

TAG _____



Engineering Specifications: Zurn AquaSpec® Z871G3-XL-HS

Polished chrome-plated 8" [203mm] brass deck faucet with an 8" [203mm] cast brass swing spout and quarter turn ceramic disc cartridges. Unit is furnished with a hose and spray, a 2.2 GPM [8.3 L] pressure compensating aerator (complying with ANSI A112.18.1 Standard for flow), 2" [51mm] vandal-resistant color-coded metal dome lever handles, mounting hardware and 1/2" NPSM coupling nuts for standard lavatory risers.

Zurn Lead Compliant* "XL" products are a line of durable, high quality brass faucets and fixtures that are designed and manufactured to comply with state laws and local codes that mandate lead content levels. Zurn "XL" products are manufactured with *not more than 0.25% lead content when used with respect to wetted surfaces of pipes and pipe fittings, plumbing fitting and fixtures: California Health & Safety Code § 116875; Vermont 9 VCA § 2470h.

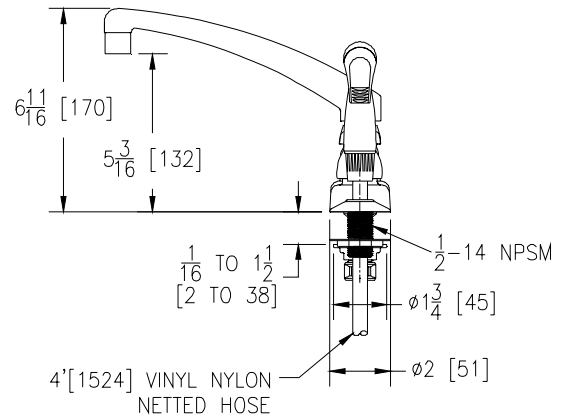
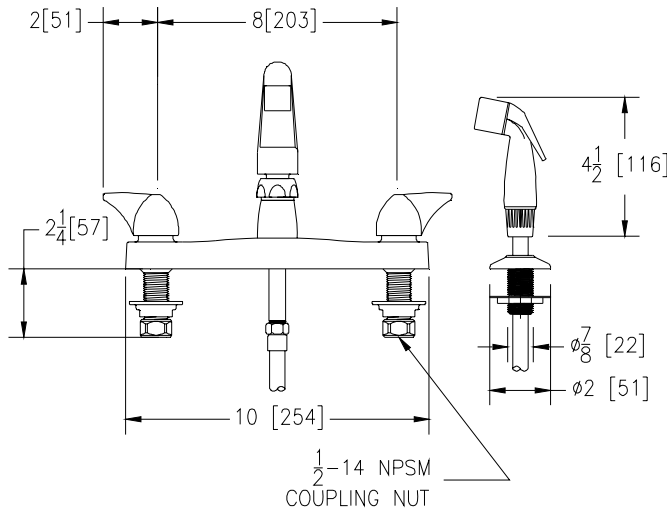

Note: All dimensions are for reference only. Do not use for pre-plumbing



OPTIONAL ACCESSORIES

Suffix	Description
___-HCT	Hot/Cold Text Indexes
___-PT	1-1/4" [32mm] Cast Brass P-Trap with a 7-1/2" [191mm] Long 17-Gauge Wall Bend
___-2F	2.2 GPM [8.3 L] Vandal-Resistant Pressure Compensating Female Aerator
___-3F	0.5 GPM [1.9 L] Vandal-Resistant Pressure Compensating Female Spray Outlet
___-4F	2.2 GPM [8.3 L] Vandal-Resistant Pressure Compensating Female Laminar Flow Outlet
___-7F	1.0 GPM [3.8 L] Pressure Compensating Female Spray Outlet
___-16F	1.0 GPM [3.8 L] Vandal-Resistant Pressure Compensating Female Spray Outlet
___-17F	1.5 GPM [5.7 L] Vandal-Resistant Pressure Compensating Female Aerator
___-18F	1.5 GPM [5.7 L] Vandal-Resistant Pressure Compensating Female Laminar Flow
___-19F	1.5 GPM [5.7 L] Anti-Microbial Pressure Compensating Female Laminar Flow Outlet
___-21F	1.0 GPM [3.8L] Pressure Compensating Female Laminar Flow Outlet
___-22F	1.0 GPM [3.8L] Vandal-Resistant Pressure Compensating Female Laminar Flow Outlet
___-23F	1.5 GPM [5.7L] Pressure Compensating Female Aerator
___-24F	0.35 GPM [1.3 L] Pressure Compensating Female Spray Outlet
___-25F	0.35 GPM [1.3 L] Vandal-Resistant Pressure Compensating Female Spray Outlet

ZURN INDUSTRIES, LLC ♦ COMMERCIAL BRASS OPERATION ♦ 2640 SOUTH WORK STREET ♦ FALCONER NY 14733

Phone: 1-800-997-3876 ♦ Fax: 1-919-775-3541 ♦ www.zurn.com

In Canada: ZURN INDUSTRIES LIMITED ♦ 3544 Nashua Drive ♦ Mississauga, Ontario L4V1L2 ♦ Phone: 905/405-8272 Fax: 905/405-1292