

INSTALLATION

Installation is no less critical than design for efficient operation of a grease interceptor. No matter how superior the design, if improperly installed, the unit's efficiency will be drastically reduced.

The interceptor should be installed as close as possible to the fixture(s) being served, as high temperature enhances grease separation. This also protects the internal piping system from grease buildup. The interceptor may be placed on the floor, partially recessed in the floor, recessed with top flush with the floor, or fully recessed below the floor, in order to accommodate piping and structural conditions. Anticipate sufficient clearance for removal of the interceptor cover and baffle for cleaning. Also, take into consideration the possibility of pipelines becoming clogged with congealed grease that may collect before reaching the grease interceptor.

Grease interceptors are not designed to perform with solid debris entering the unit. Solid material should not be permitted to enter the grease interceptor. In an application where solids are present, a solids interceptor is recommended to be used in conjunction with the grease interceptor. Grease tends to attract solid particles, growing in size and promoting decay, leading to unpleasant odor and unsanitary conditions. Under these conditions, pipes can readily become clogged and even the grease interceptor itself may fill up with debris.

All sink and garbage grinder waste must pass through a solids interceptor because rapid accumulation of solid matter will greatly reduce the grease interceptor efficiency, preventing operation in compliance with its rated capacity. A separate grease interceptor is recommended for each commercial dishwasher. The size of the interceptor is determined by the discharge rate of the dishwasher as specified by the manufacturer (Diagram B).

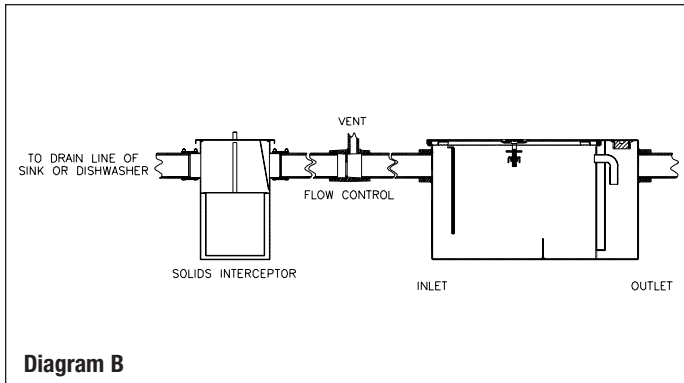

Placement of the interceptor in a high traffic area is an important concern. If the interceptor is to be installed flush with the floor, it is necessary to determine whether or not the interceptor will experience heavy-duty load traffic. The standard grease interceptor is designed for foot and light traffic only. If a greater load rating is required, the interceptor must be constructed accordingly to accept the higher load.

FLOW CONTROL

The use of a flow control device (Z1108), furnished with all grease interceptors, is an important factor in the operation of the interceptor. Grease interceptors are designed to work properly within certain flow conditions. A flow control device placed as close to the source of liquid as possible is an important component of the assembly. The flow control device should be installed in the waste line upstream of the grease interceptor. It should be placed beyond the last connection from the fixture(s) and as close as possible to the underside of the lowest fixture. When two or more sinks or fixtures are combined and served by one interceptor, a single flow control fitting can be used. Air intake for the flow control device may terminate under the sink drain board, as high as possible, to prevent overflow or terminate in a return bend at the same height outside of the building. When a fixture is individually trapped and backvented, air intake may intersect the vent stack. All installation recommendations are subject to approval of code authority.

The air intake of the flow control must be plumbed in to either the vent stack or above the flood rim of the sink. Without a properly vented flow control device, effluent flows may exceed the rated capacity of the interceptor, causing incoming fluids to be passed through the unit before proper separation can be achieved (Diagram C). The result would be grease buildup downstream, defeating the purpose of the interceptor.

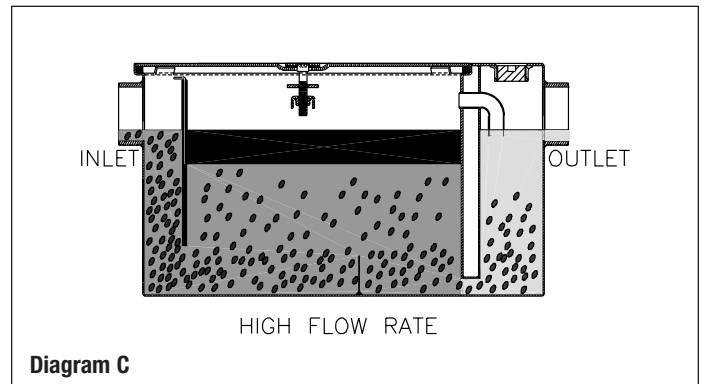

Equilibrium in the separation chamber of the interceptor is maintained by air pressure. The Zurn interceptor design incorporates two features to maintain equilibrium: 1) Vented flow control device, and 2) Air relief by-pass.

INSTALLATION

FLOW CONTROL, Continued

The flow control device must be properly vented to permit air to properly mix with the fluid entering the interceptor. Air facilitates separation and, more importantly, is necessary to maintain the proper pressure and thus the proper operating level within the separation chamber. For example, without a properly vented flow control device, little or no air would be drawn into the interceptor during use, causing the operating level to rise, pushing the grease cake toward the cover (Diagram D). If the grease layer reaches the air relief by-pass, grease could be pushed on into the outlet.

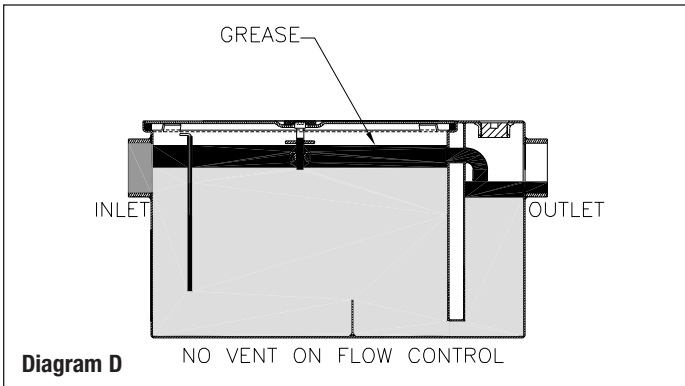

If air enters an interceptor that does not utilize an air relief by-pass, the buildup in air pressure has nowhere to go and begins pushing the grease and water layers downward toward the bottom of the interceptor (Diagram E). If pressure continues to build, grease would eventually be forced under the baffle plate and out of the unit.

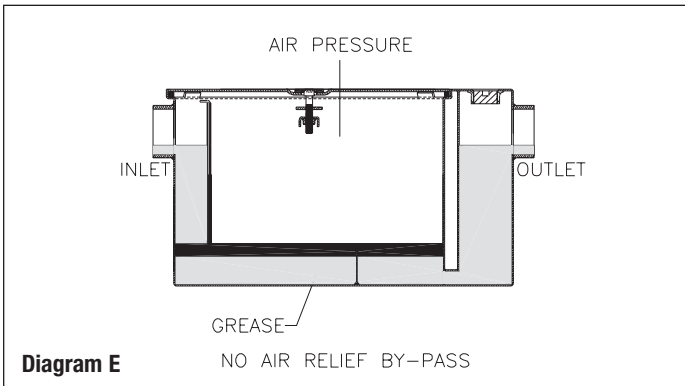

The presence of a vented flow control device and air relief by-pass is a key element in the efficient operation of a grease interceptor. If one or both of these items are not present, flow rate through the interceptor and operational performance can be severely compromised.

NEED FOR A FLOW CONTROL DEVICE

A grease interceptor, correctly designed to separate light density substances from wastewater, will not by itself govern or regulate the flow of water through the interceptor at all times to sufficiently assure the “flotation” separation of the substances which are to be intercepted at maximum efficiency. The flow control device is designed with an integral orifice to give a predetermined optimum flow rate and air intake to the interceptor. The orifice openings are related to the size and flow rating of the grease interceptor.

Standard orifice sizing is for gravity flow conditions where no pressure buildup is considered. If an interceptor is operating at maximum flow levels, a head may develop, in which case overload conditions may still exist.

Trap Flow Rate Size GPM	Standard Size Orifice Inches
4	5/8
7	5/8
10	15/16
15	15/16
20	1-1/4
25	1-1/4
35	1-1/2
50	1-3/4
75	2-1/4
100	2-1/4
125	2-5/8
150	2-5/8
200	3-1/4
250	3-1/4
300	4
400	4-1/2
450	4-1/2
500	4-7/8

INSTALLATION

Z1108/Z1108-L FLOW CONTROL FITTING

Every interceptor should have a flow control fitting and flow control fittings should be properly vented. The flow control fitting is installed in line between fixture and interceptor. Its function is to regulate the

flow so that it will not exceed the flow rate capacity of the interceptor, thus ensuring fool-proof operation and maximum efficiency.

Z1108 DIMENSIONAL DATA

A (IP)	B	C	D
1-1/2	5-7/16	2-7/8	3-13/16
2	5-7/16	2-7/8	3-13/16
3	6-1/8	4	4-1/8
4	6-13/16	5	4-3/4

Z1108-L DIMENSIONAL DATA

A	B	C	D
1-1/2	5-3/4	3-3/8	1-7/8
2	5-3/4	3-3/8	1-7/8
3	6-3/8	3-3/4	2-3/4

Z1108

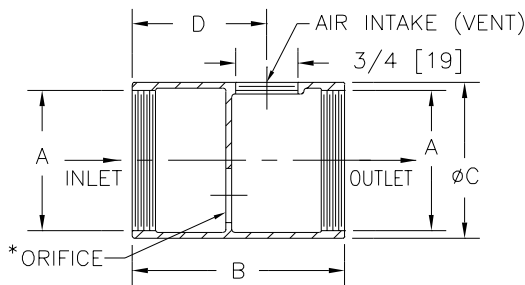

*Orifice size varies according to size of interceptor.

Z1108-L

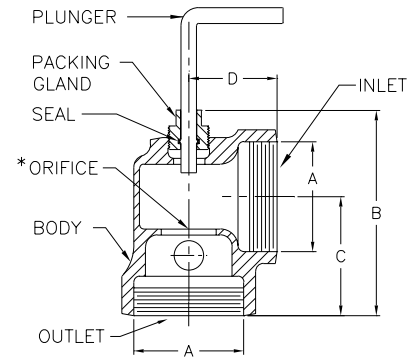

SETTINGS FOR ZURN FLOW CONTROL FITTING

Consider a Z1170, #300 Interceptor, rated at 10 GPM, installed with the Z1108 or Z1108-L flow control fitting. When installed with a scullery sink in compliance with PDI standards for grease interceptors, this interceptor can be recessed in the floor (shown solid) or placed on the floor (shown dotted).

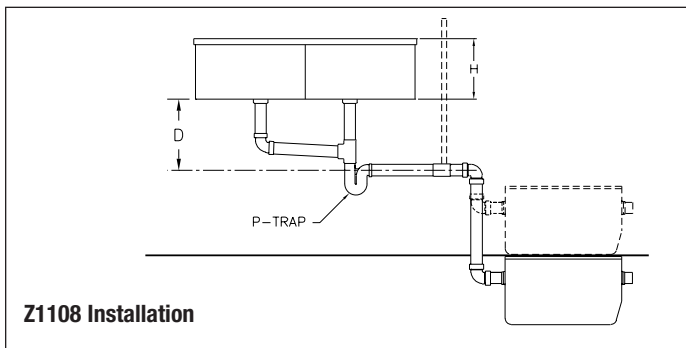

Z1108 Installation

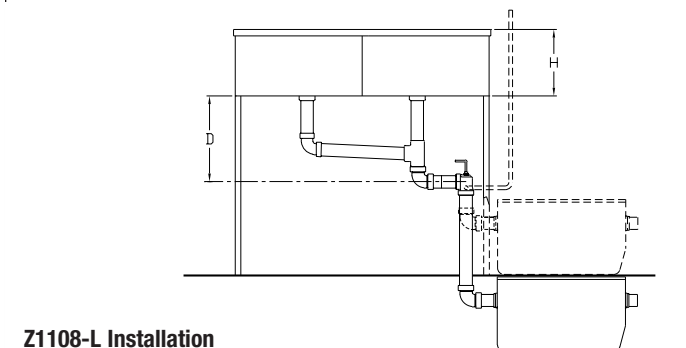

Z1108-L Installation

'H' SINK DEPTH	INTERCEPTOR SIZE							
	100	200	300	400	500	600	700	800
*D' Dimensions in Inches								
6	7.5							
6.5	7.5		10	10	10			
7	6.75	7.5	10	10	10			
7.5	6.75	7.5	9.25	9.25	9.25			
8	6.0	6.75	9.25	9.25	9.25			
8.5		6.75	8.5	8.5	8.5			
9		6.0	8.5	8.5	8.5			
9.5			7.75	7.75	7.75			
10			7.75	7.75	7.75			
10.5			7.0	7.0	7.0	10.0	10.0	11.0
11			7.0	7.0	7.0	10.0	10.0	11.0
11.5			6.5	6.5	6.5	9.25	9.25	10.5
12						9.25	9.25	10.5
12.5						8.5	8.5	9.5
13						8.5	8.5	9.5
13.5						7.75	7.75	9.0
14						7.75	7.75	9.0
14.5						7.0	7.0	8.0
15						7.0	7.0	8.0
15.5						5.0	5.0	7.5
16								7.5
18								5.75

Note: All figures represent maximum distances in inches. Figures between horizontal lines are recommended.

VENTING

Grease interceptors must have a vented waste, sized in accordance with code requirements for venting traps, to retain a water seal and to prevent siphoning.

MULTIPLE FIXTURE INSTALLATION

One interceptor to serve multiple fixtures is recommended only where fixtures are located close together. In such installations, each fixture should be individually trapped and back-vented.