

SANI-GARD Z1022

Z1022 Sani-Gard Trap Primer

The Zurn Trap Primer is a necessity in areas where drains are infrequently used and provides positive protection to maintain trap seals. The Zurn Z1022 automatic trap primer, properly installed in the supply line to a fixture, will automatically supply water to the deep seal P-trap of a drain each time the fixture is used. When the fixture is used, water is delivered to the trap of the floor drain which is serviced by the trap primer. The piston inside the trap primer raises when water flows through the supply line, thus allowing water to flow into the trap.

Engineering Specification: Zurn Z1022 Sani-Gard Automatic Trap Primer, all bronze body with integral vacuum breaker, non-liming internal operating assembly with gasketed bronze cover.

A - Pipe Size/Connection	L [mm]	Approx. Wt. Lbs. [kg]
1/2" [13] Solder Female	3-1/4" [83]	1 [.5]
1/2" [13] IP Female	3-1/4" [83]	1 [.5]
1/2" [13] Solder Female Union	5-11/16" [144]	1.5 [.75]
1/2" [13] IP Female Union	5-3/8" [137]	1.5 [.75]

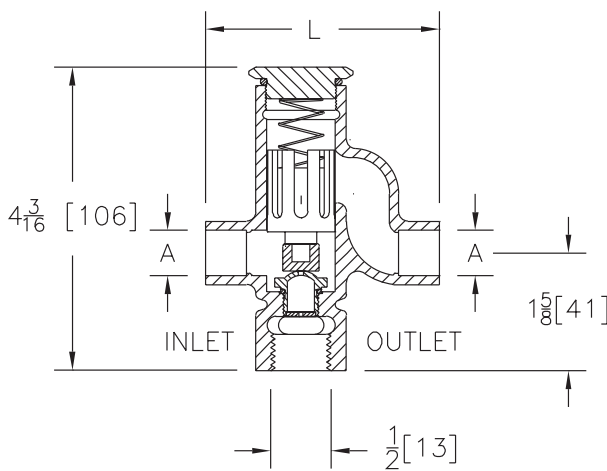
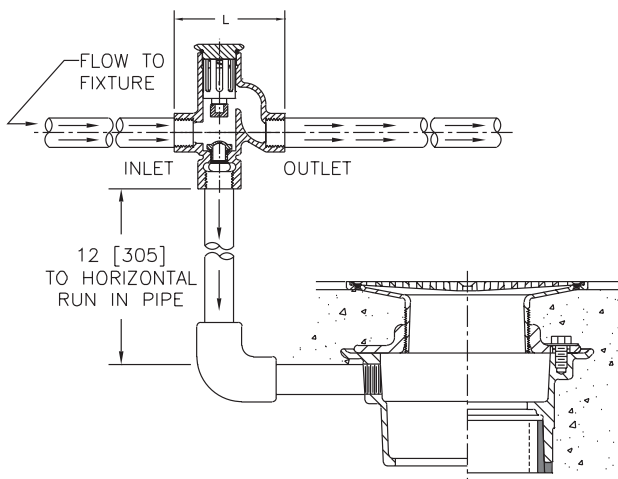

Note: Trap primer should be installed a minimum of 6" above grid of floor drain or flood level rim of equipment served.

Installation

Water supply lines should be flushed clear of chips and debris when possible, before installing the Zurn automatic trap primer.

Install a frequently used horizontal cold water line above the trap to be protected. The trap primer valve should be installed vertically at least 12 inches above the grid of a floor drain, or the flood rim of the equipment which the trap is to serve.

Note: Remove the piston during the soldering process. Replace the piston once the soldering is completed.

After the unit is installed, check through the vacuum breaker ports to see that water flows to the drain trap when the cold water line is flowing, and that the valve shuts off when the water line is closed.

Note: In order to operate the trap primer at static pressures between 20 and 80 psi, a pressure drop of 2 to 3 psi is required.

Maintenance

The Zurn 1022 trap primer requires little maintenance. A periodic visual inspection through the air gap vacuum ports of the Z1022 or drain trap will ensure proper operation.

Situations may arise where the trap primer, drain line, or drain body must be installed in an application that has construction limitations. These limitations, such as installation in a pre-existing floor that cannot be easily altered, can make connecting the trap primer to the drain body very difficult. Requirements, like drain line height or proper sloping of the drain line to the drain body, cannot always be met.

Flow Rate Through a 0.5 to 2.0 GPM Faucet Aerator

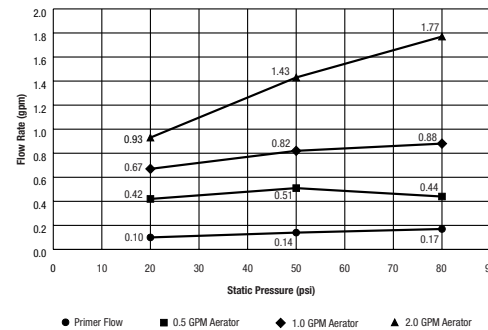

Troubleshooting

No water to drain	<ol style="list-style-type: none"> 1. Check flow rate at the fixture. Minimum flow rate must be 0.5 GPM or higher. 2. Inspect piston seat for dirt or debris that may clog the orifice opening. 3. Drain line is plugged downstream of the trap primer. 4. Trap primer is installed backward.
Continuous water to the drain	<ol style="list-style-type: none"> 1. Inspect piston seat for dirt or debris that may prevent the piston from fully seating. 2. Inspect gasket seal of piston for any damage. 3. Remove the piston seat and inspect the O-ring for damage.
Water spraying out of vacuum breaker ports	<ol style="list-style-type: none"> 1. Drain line is reduced down, restricting the flow from the trap primer. Drain line size must be at least 1/2" pipe. 2. Inspect the piston seat for clogging. Debris lodged inside the piston seat may divert the flow of water to stream outward, spraying through the air gaps. 3. Drain line is plugged or is piped to create a trap seal, causing water to back up in the line. 4. Check to ensure that the piston seat is free of any burrs that may redirect the flow of water to the drain line.