



Z539

12 [305] HEAVY-DUTY DRAIN WITH DEEP SUMP

SPECIFICATION SHEET

TAG _____

Dimensional Data (inches and [mm]) are Subject to Manufacturing Tolerances and Change Without Notice

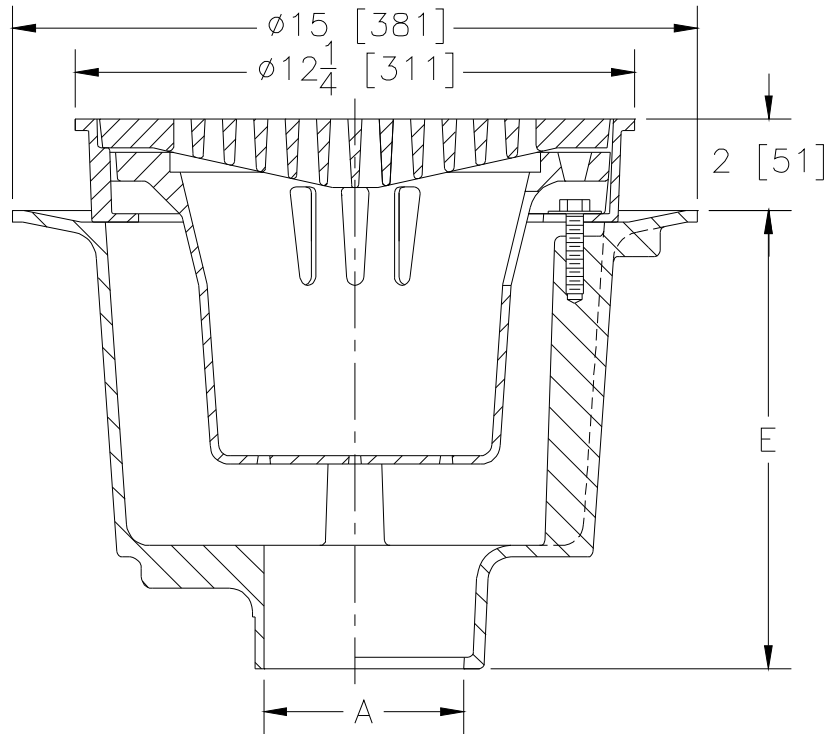

A- Pipe Size In.	Approx. Wt. Lbs. [kg]	Grate Open Area Sq. In. [cm ²]
3-4-6 [76-102-152]	68 [31]	30 [194]
8 [203]		

ENGINEERING SPECIFICATION: ZURN Z539
 12 [305] Diameter top drain, Dura-Coated cast iron deep sump body with bottom outlet, seepage pan and combination membrane flashing clamp and frame for sediment bucket and heavy-duty slotted grate.

OPTIONS (Check/specify appropriate options)

PIPE SIZE	(Specify size/type)	OUTLET	'E' BODY HT. DIM.
3-4-6 [76-102-152]	_____	IC Inside Caulk	10 [254]
3-4-6 [76-102-152]	_____	IG Inside Gasket	10 [254]
3-4-6-8 [76-102-152-203]	_____	NH No-Hub	10 [254]

PREFIXES

- _____ Z D.C.C.I. Body and Top*
- _____ ZB D.C.C.I. Body with Polished Bronze Top (Add 3/16 [5] to 2 [51] Dim. and 3/4 [20] to 12-1/4 [311] Dim.)
- _____ ZN D.C.C.I. Body with Polished Nickel Bronze Top (Add 3/16 [5] to 2 [51] Dim. and 3/4 [20] to 12-1/4 [311] Dim.)

SUFFIXES

- _____ -DG Duresist Grate
- _____ -G Galvanized Cast Iron
- _____ -H Hinged Grate
- _____ -HP Heel-Proof Grate
- _____ -SS Stainless Steel Mesh Liner for Bucket
- _____ -T Square Top
- _____ -TS Top Secured with Slotted Screws
- _____ -VP Vandal-Proof Secured Top
- _____ -YF Free Standing Bucket

REV. H	DATE: 11/22/10	C.N. NO. 120470
DWG. NO. 58942	PRODUCT NO. Z539	

*REGULARLY FURNISHED UNLESS OTHERWISE SPECIFIED