



Z1719 DECK DRAIN WITH WIDE FLANGE

SPECIFICATION SHEET

TAG _____

Dimensional Data (inches and [mm]) are Subject to Manufacturing Tolerances and Change Without Notice

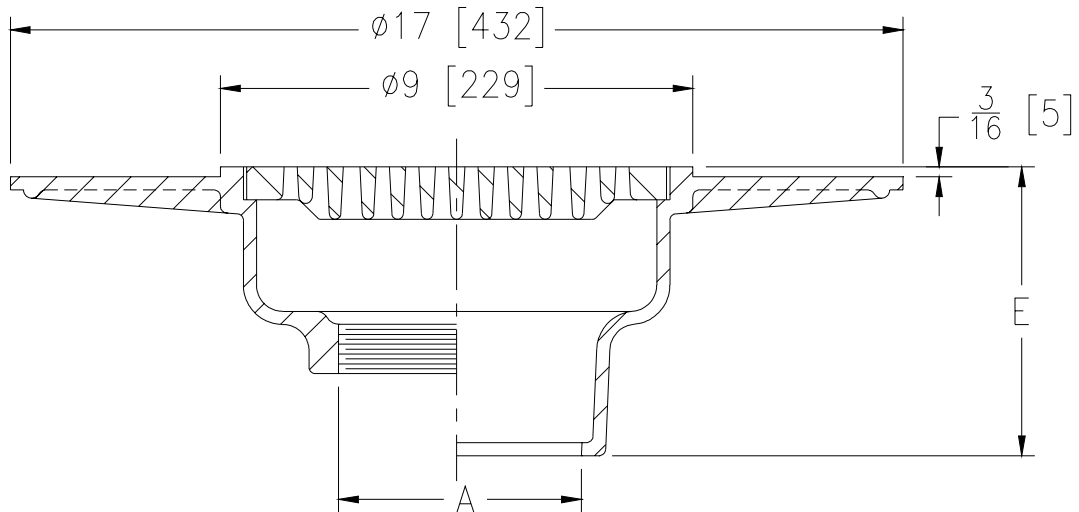

A- Pipe Size In.	Approx. Wt. Lbs. [kg]	Grate Open Area Sq. In. [cm ²]
2-3-4 [50-75-100]	22 [10]	17 [110]

ENGINEERING SPECIFICATION: ZURN Z1719 All Type 304 (CF8) stainless steel deck drain with 17 [432] diameter flange and medium duty flat grate with plain finish.

OPTIONS (Check/specify appropriate options)

PIPE SIZE

2-3 [50-75]
2 thru 4 [50 thru 100]

(Specify size/type) **OUTLET**

_____ IC Inside Caulk
_____ IP Threaded

'E' BODY HT. DIM.

5 1/2 [140]
4 [102]

PREFIXES

_____ Z Type 304 (CF8) Stainless Steel Body*
_____ ZC Type A-27 Carbon Steel Body (P.O.A.)
_____ ZM Type 316 (CF8M) Stainless Steel Body

SUFFIXES

_____ -SF Satin Finish Top
_____ -TS Top Secured with Slotted Screws
_____ -VP Vandal-Proof Secured Top
_____ -Y Sediment Bucket

REV. C	DATE: 11/5/03	C.N. NO. 91601
DWG. NO. 59288	PRODUCT NO. Z1719	

*REGULARLY FURNISHED UNLESS OTHERWISE SPECIFIED