

Model ZW1017

Aqua-Gard Tempering Mixing Valve

WILKINS
a ZURN® company

□ Installation □ Maintenance Instructions

INSTALLATION INSTRUCTIONS

It is suggested that the device be installed with a shut-off valve and a thermometer on the tempered water line to provide accurate and safe water mixing temperatures. This device should never be used to deliver water to the point of use end user. This ASSE 1017 approved device is to be used with an ASSE 1016 approved device. A tempering valve is designed to mix cold water and hot water from a hot water heater to a safer temperature of 122°F(50°C) or less.

1. Flush the Hot and Cold delivery lines completely before installing the device.
2. The device can be installed in any position. Note: the inlet hot supply is to be connected to the "H" side of the valve and the cold supply side to the "C" side.
3. The valve is to be fitted to deliver mixed water to a single tempered water outlet.
4. To set the temperature on the valve remove the protective blue cap. The cap can be removed by inserting a small blade screw driver into the slot at the base of the blue cap and lightly push up. Using an adjustable wrench or combination wrench, rotate the flats clockwise to lower the temperature or counter-clockwise to increase the set temperature. Read temperature with a thermometer.
5. Verify the set temperature by running a plumbing fixture and and reinstall the protective plastic cap to the device.
For bathroom operation set the maximum temperature not to exceed 122°F (50°C).

PERFORMANCE

Outlet Temp. Range	95-131°F(35-55°C)
Temperature Hot Supply	120-195°F max. (49-90.5°C)
Temperature Cold Supply	40-75°F(4.4-23.8°C)
Set Temperature Accuracy	+/- 4°F(2°C)
Max. Working Pressure (inlet)	145 psi
FACTORY SET	118°F(47.8°C)
Max. Working Pressure (Dynamic)	1.5-70 psi
Flow rate @ 45 psi pressure loss	18 gpm
Min. Flow Rate	0.5 gpm

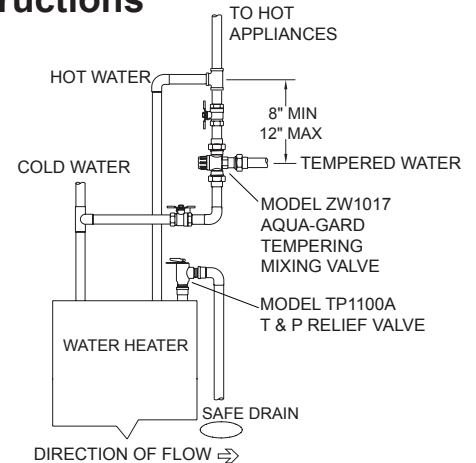

DOMESTIC WATER HEATER APPLICATION

PIPING INSTRUCTIONS

The device is designed to be installed at or near a hot water heater. When installing at or near a hot water tank be sure to have the valve mounted below the hot water high temperature line. This will keep the Tempering valve from by-passing and going to high temperature, in the event that debris has clogged the control cartridge or screens.

CAUTION: Installation of water temperature control products must be performed by qualified, licensed personnel. The qualified installer should be sure that the proper device has been selected correctly for the proper installation. A faulty installation can cause scalding, severe injury or death.

NOTICE: Annual inspection and maintenance is required of all plumbing system components. To ensure proper performance and maximum life, this product must be subject to regular inspection, testing and cleaning.

WARNING! Water Temperature in Excess of 122°F(50C) Is Dangerous and Will Cause Scalding, Severe Injury or Death! This valve is Factory preset 118°F(47.8°C). To deliver a safe mixed water temperature at the outlet, the installer must use a thermometer at the outlet to verify the temperature. **WARNING!** This valve is not to be used for point of usage. This valve is not to be used as a Anti-scald device. This valve must be used in conjunction with a ASSE 1016 approved device.

MODEL	INLET & OUTLET	DIMENSIONS (approximate)						WEIGHT	
		A		B		C		lbs.	kg
		in.	mm	in.	mm	in.	mm		
38-ZW1017COMP	3/8" compression	5 11/16	145	3 5/8	92	5 13/16	148	2	1
12-ZW1017	1/2" FNPT	5 7/16	138	3 3/8	86	5 1/4	133	2	1
12-ZW1017C	1/2" CU Sweat								
12-ZW1017CPVC	1/2" CPVC	5 7/8	149	3 13/16	97	6 3/16	157	2	1
12-ZW1017PEX	1/2" Barb	5 9/16	141	3 1/2	89	5 9/16	141	2	1
34-ZW1017	3/4" FNPT	5 1/2	140	3 1/2	89	5 7/16	138	2	1
34-ZW1017C	3/4" CU Sweat								
34-ZW1017CPVC	3/4" CPVC	5 7/16	138	3 3/8	86	5 5/16	135	2	1
34-ZW1017PEX	3/4" Barb	5 9/16	141	3 1/2	89	5 9/16	141	2	1
34-ZW1017M	3/4" MNPT	6 1/4	159	4 1/4	108	7	178	2	1
1-ZW1017C	1" CU Sweat	5 1/2	140	3 7/16	87	5 3/16	132	2	1

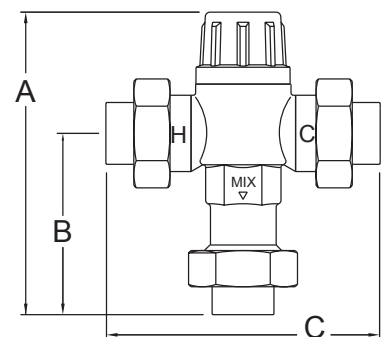

WARRANTY: WILKINS Valves are guaranteed against defects of material or workmanship when used for the services recommended. If in any recommended service, a defect develops due to material or workmanship, and the device is returned, freight prepaid, to WILKINS within 12 months from date of purchase, it will be repaired or replaced free of charge. WILKINS' liability shall be limited to our agreement to repair or replace the valve only.

Proposition 65 Warning This product contains chemicals known to the State of California to cause cancer or birth defects or other reproductive harm.

This product is not to be used to convey water for human consumption through cooking or drinking in California or Vermont.
California H&S Code §116875, VSA §2470h

MATERIALS

Body	Bronze ASTM B 584 UNS C83600
Internal brass	DZR Brass
Piston	Polysufone
Guide Tube	Noryl GFN2
Spring & Screen	300 Series Stainless Steel
Seals	Nitrile Elastomer
Checks	Noryl GFN2

MAINTENANCE

SERVICING THE STRAINERS

The strainers on the inlet supplies can be serviced by loosening the union nuts, removing the valve from service and clean the screens thoroughly with water after disassembly. Where water quality is a concern it may be necessary to install additional line strainers.

SERVICING THE CHECK VALVES

The check valves can be serviced by removing them from the body. Flush the check valves thoroughly with water removing debris from the seat and seat washers. Reinstall the check valve by pushing them into the body flush to the body, spring first. Make sure that the poppet and seat washer is facing you.

OPERATION

The valve internals themselves cannot be serviced. If the valve fails it must be replaced. The function of the valve can be checked by measuring the temperature of the water at the outlet nearest to the valve. If the temperature is within +/- 4°F of the initial set temperature, the valve is functioning correctly. If the temperature has changed by more than +/- 4°F it is likely due to a build up of debris in the strainers or a change in the supply condition.

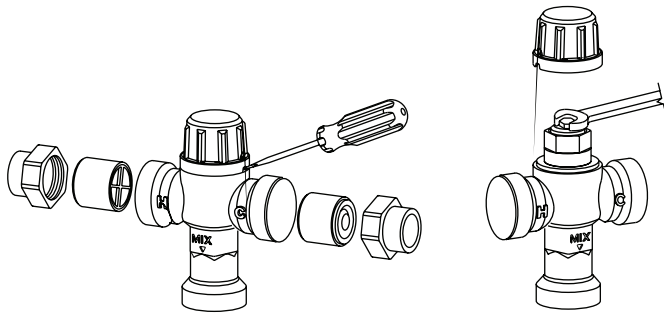

Removing Cap

Temperature Adjustment

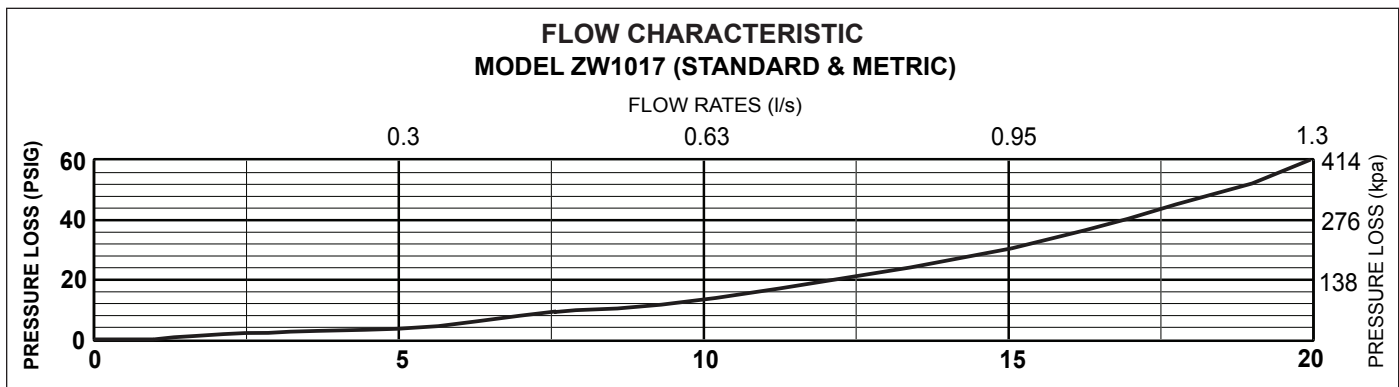

TROUBLESHOOTING

PROBLEM	CAUSE	SOLUTION
The desired mixed water temp. cannot be obtained or valve is difficult to set	Hot and cold supplies are reversed, valve is full of debris or strainers are fouled	Refit valve so H & C are correct, flush valve with water and clean strainers
Mix. Temperature is unstable	Strainers are fouled or fluctuating supply pressure	Clean strainers and Install PRV's on H & C inlet supplies
Mix Temperature changing over time	Fluctuating supply pressures or strainers are full	Install PRV's and clean strainers
Either full Hot or Cold water flowing	Valve is set incorrectly	Adjust mix. Temperature to 95-115°F
No flow from the valve outlet	Hot or Cold water supply failure or strainers are fouled	Restore inlet supply & check mix. Temperature and clean strainers
Flow rate reduced or fluctuating	Valve or inlet fitting fouled by debris	Check valve and inlet fittings for blockage
Mixed water temp. too Hot or Cold	Valve has been tampered with, valve incorrectly set, or inlet temperatures are not within specified limits	Re-adjust to required set temp. to ensure inlet temperatures are within specified limits
Mixed water temp. does not change when the temp. adjuster is moved	Hot and Cold supplies are reversed	Refit the valve to correct Hot and Cold
Hot water flows into the cold water system or vice versa	Check valve is fouled	Clean strainers and remove debris
Valve is noisy	Water velocity is too high	Reduce water velocity



WILKINS, a ZURN company

1747 Commerce Way, Paso Robles, CA 93446 Phone:805/238-7100 Fax:805/238-5766