

SPECIFICATION SUBMITTAL SHEET

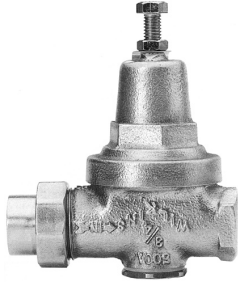

FEATURES

- Sizes: 1/2" 3/4" 1" 1 1/4"
 1 1/2" 2" 2 1/2" 3"
- Maximum working water pressure 300 psi
Maximum working water temperature 180° F
Reduced pressure range 25 psi to 75 psi
Factory preset (fieldset 2 1/2" & 3") 50 psi
Threaded connections (FNPT) ANSI B1.20.1
Copper connections (FC) ANSI B 16.22
CPVC tailpiece: Max.hot water temp. 180°F @ 100 psi
Cold water rated temp. 73.4°F @ 400 psi

OPTIONS (Suffixes can be combined)

- standard with single union FNPT inlet x FNPT outlet (1/2" thru 2") and less union (2 1/2" & 3")
- C - copper sweat connection (1/2" thru 2")
- HR - 75 psi to 125 psi spring range, factory set at 85 psi (fieldset 2 1/2" & 3")
- HLR - 10 psi to 125 psi spring range, factory set at 50 psi
- HT - 210°F maximum temp
- L - less integral by-pass check valve (3/4"-2")
- LPV - 210°F maximum temp with 10 psi to 35 psi spring range, factory set at 20 psi
- LPC - 180°F maximum temp with 10 psi to 35 psi spring range, factory set at 20 psi
- SC - sealed cage bell housing and stainless steel adjustment screw
- SW - made for salt water service
- YSBR - with bronze "Y" strainer on inlet
- 510 - 400 psi inlet rating and 75 psi to 125 psi spring range, factory set at 85 psi (fieldset 2 1/2" & 3")
- P - tapped and plugged for gauge
- CPVC - CPVC tailpiece connection (3/4"-1")

ACCESSORIES

- Repair kit (rubber only)

DIMENSIONS & WEIGHTS (do not include pkg.)

APPLICATION

Designed for installation on potable water lines to reduce high inlet pressure to a lower outlet pressure. The high flow capacity makes this device most suitable for industrial water lines and commercial irrigation systems. The direct acting integral by-pass design prevents buildup of excessive system pressure caused by thermal expansion. The balanced piston design enables the regulator to react in a smooth and responsive manner to changes in system flow demand, while at the same time, providing protection from inlet pressure changes.

STANDARDS COMPLIANCE

- ASSE® Listed 1003 (1/2" thru 2 1/2")
- IAPMO® Listed (1/2" thru 2")
- City of Los Angeles Approved (1/2" thru 3")
- CSA® Certified (1/2" thru 2")

MATERIALS

Main valve body	Cast bronze	ASTM B 584
Access covers	Cast bronze	ASTM B 584
	Brass	ASTM B 16
Fasteners	Stainless steel, 300 series	
Stem & plunger	Cast bronze	ASTM B 584
	Brass	ASTM B 16
Elastomers	Buna Nitrile (FDA approved)	
	EPDM (FDA approved)	
Cap gaskets	Natural vulcanized fibre	
	Acetal (Delrin™ 500), NSF Listed	
Springs	Oil tempered wire, ASTM A 229	
Seat	Stainless steel, 300 series	

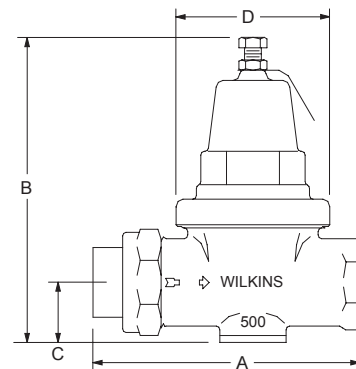

SIZE		CONNECTIONS	DIMENSIONS (approximate)								WEIGHT	
			A		B		C		D		lbs.	kg.
in.	mm		in.	mm	in.	mm	in.	mm	in.	mm		
1/2	15	SINGLE UNION	4 1/2	108	6	152	1 5/8	41	2 3/4	70	3	1.5
3/4	20	SINGLE UNION	4 5/8	118	6	152	1 1/8	29	2 3/4	70	4	2.0
1	25	SINGLE UNION	5 1/8	130	6 7/8	175	1 5/8	41	3 5/16	84	6	3.0
1 1/4	32	SINGLE UNION	6 5/16	160	7 1/4	184	1 3/4	45	4	102	7	3.0
1 1/2	40	SINGLE UNION	8 5/16	211	10	254	1 7/8	48	5	127	14	6.5
2	50	SINGLE UNION	9 1/2	241	10 3/4	273	2 1/8	54	6 1/2	165	20	9.0
2 1/2	65	LESS UNION	10	254	14 1/2	368	3	76	8	203	28	12.5
3	80	LESS UNION	11 1/8	283	16	406	3 1/2	89	8	203	44	20.0

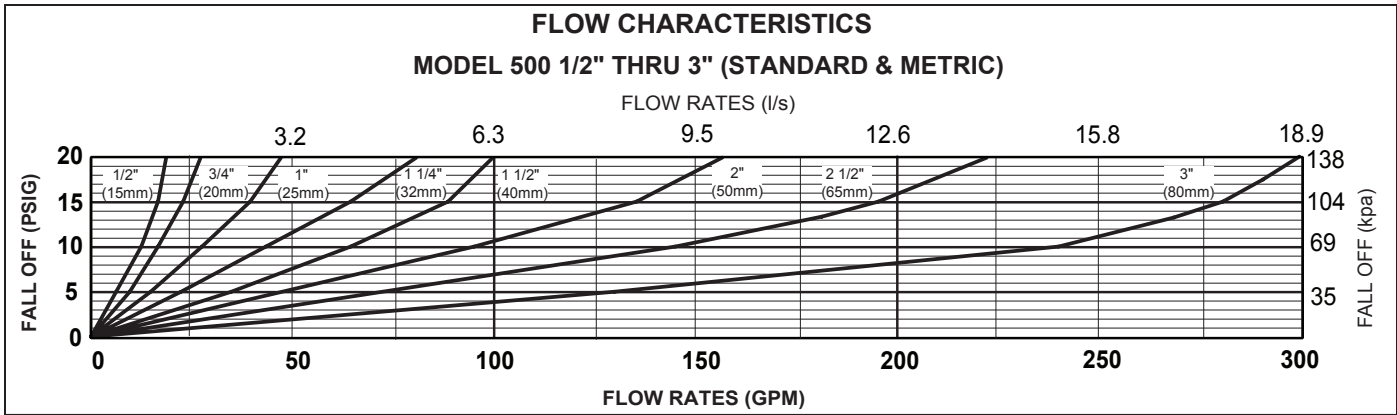

TYPICAL INSTALLATION

Local codes shall govern installation requirements. Unless otherwise specified, the assembly shall be mounted in accordance with the manufacturers' instructions and the latest edition of the Uniform Plumbing Code. The assembly shall be installed with sufficient side clearance for testing and maintenance. The Model 500 may be installed in any position. If installed in a pit or vault, specify the "SC" sealed cage option. Multiple installations are recommended for wide demand variations or where the desired pressure reduction is more than 4 to 1 (i.e.: 200 psi inlet reduced to 50 psi outlet).

CAUTION: Anytime a reducing valve is adjusted, a pressure gauge must be used downstream to verify correct pressure setting. Do not bottom adjustment bolt on bell housing.

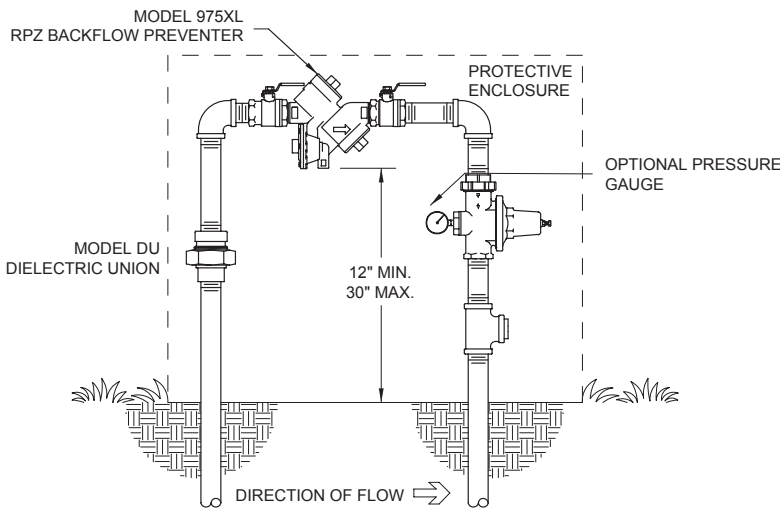

TYPICAL INSTALLATION

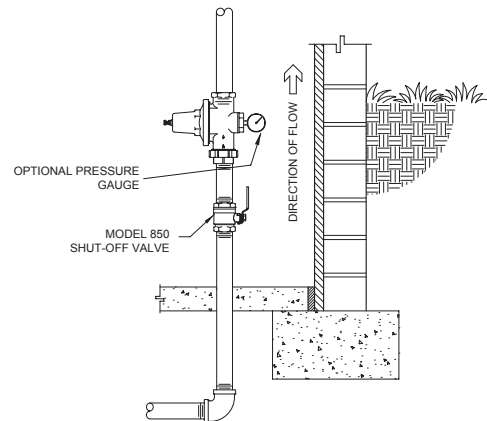

VERTICAL INSTALLATION

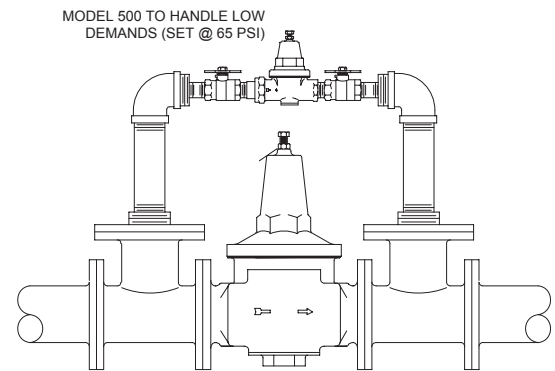

BATTERY INSTALLATION

SPECIFICATIONS

The Pressure Reducing Valve shall consist of a bronze body and bell housing, a separate access cover for the plunger and a bolt to adjust the downstream pressure. The bronze bell housing and access cap shall be threaded to the body and shall not require the use of ferrous screws. The assembly shall be of the balanced piston design and shall reduce pressure in both flow and no-flow conditions. The assembly shall be accessible for maintenance without having to remove the body from the line. The Pressure Reducing Valve shall be a WILKINS Model 500.