



2-Wire Zone Valve Actuator – QHVZDM

Specification Sheet

Tag _____

Dimensional Data: Inches and [mm] are subject to manufacturing tolerances and change without notice.

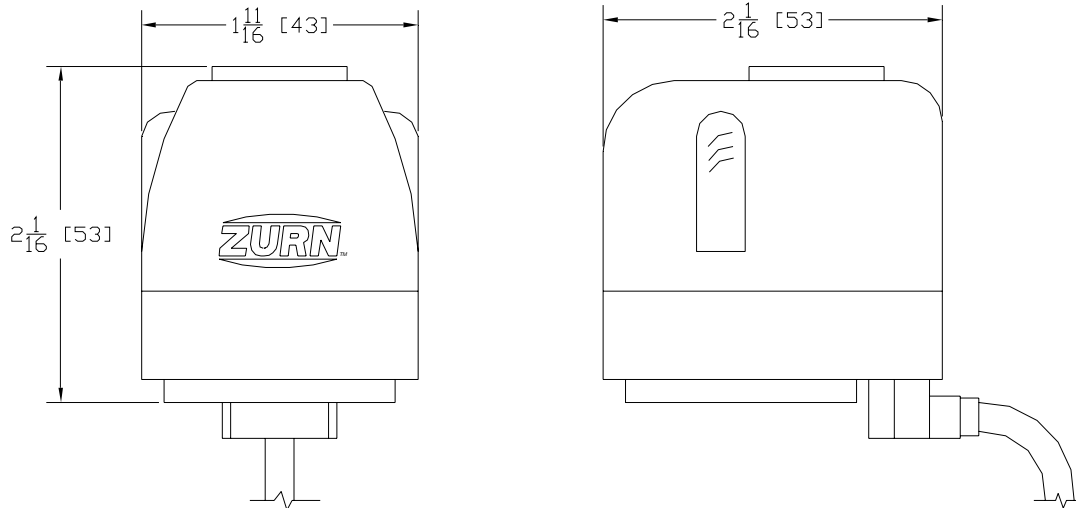

Engineering Specification: Zurn Zone Valve Actuator allows for zone valve control. Unit operates on 24VAC, 2W. Complete with pop-up indicator. Connects to zone valve with threaded adapter and actuator is snap on/off to adapter.

Accessories

___ QHMZ4A	4-Zone Valve Control
___ QHMZ6A	6-Zone Valve Control
___ QHDV5	1" 3-Way Diverter Valve
___ QHSZV33	1/2" Straight Zone Valve
___ QHSZV44	3/4" Straight Zone Valve
___ QHSZV55	1" Straight Zone Valve
___ QHSZV66	1-1/4" Straight Zone Valve
___ QHAZV33	1/2" 90° Angle Zone Valve

Rev.	Date: 6/4/02	C.N. No.89569
Dwg. No. 66744		Prod. No. QHVZDM