



**ARCHITECTURAL/ENGINEERING SPECIFICATION**

The ZER EZ Gear-Driven Water Closet Flush Valve is performance engineered with the dual action of the ceramic disc cartridge and motor gear-driven operation. Its polished chrome-plated finish, modern top-mount design, and quiet diaphragm operation are ideal for new and retrofit commercial restroom applications.

**PRODUCT FEATURES**

- Zurn's TPE diaphragm
  - Clog-resistant bypass
  - Chloramine resistant
- Actuator
  - Electronic automatic sensor
  - Gear-driven ceramic cartridge
- True Mechanical Override Button
- Control Stop
  - Internal siphon-guard protection
  - Vandal-resistant stop cap
  - Sweat solder kit
  - Cast wall flange with set screw
- Vacuum Breaker
  - High back pressure
  - One piece hex coupling nut
- Chloramine-resistant internal seals
- Adjustable tailpiece
- Spud coupling and flange for top spud connection
- Operating Pressure
  - 25 psi (running) - 80 psi (static)
  - Higher running pressure may be required for some fixtures. Consult fixture manufacturer for details.

**ACCESSORIES (ORDER SEPARATE AS SPECIFIED)**

- P6900-ACA 7.5VDC Plug-In ACA Power Supply  
Powers up to 4 valves
- P6000-HW6 7.6VDC Hardwired Power Converter  
Powers up to 8 valves

**COMPLIANCE AND CERTIFICATION**

- Complies with ASSE 1037/ASME A112.1037/CSA B125.37
- ADA Compliant



\*This product should be used with a WaterSense labeled counterpart with a compatible flow volume to ensure that the entire system meets the requirements for water efficiency and performance.

**WHEN INSTALLING IN A HANDICAP STALL:**

Per the ADA Guidelines (section 604.9.4) it is recommended that the grab bars be split or shifted to the wide side of the stall. If grab bars must be present over the valve, use the alternate ADA installation as shown.



**FLOW OPTIONS**

	FLUSH VOLUME GPF	DUAL FLUSH GPF	WATERSENSE* COMPLIANT
<b>-ONE</b>	1.1		☑
<b>-HET</b>	1.28		☑
<b>-WS1</b>	1.6	1.6/1.1	

**SUFFIX OPTIONS**

- DF Dual Flush (See Chart Above)
- YJ Split Ring Pipe Support
- YK Solid Ring Pipe Support

**VALVE HEIGHT OPTIONS**

	DIMENSION A INCH [MM]
<b>-STANDARD</b>	11 1/2" [292]
<b>-1</b>	16" [406]
<b>-2</b>	24" [610]
<b>-3</b>	27" [686]

**ARCHITECTURAL & ENGINEERING APPROVAL**

The information contained in this document is subject to change without notice. Please contact Zurn for most up to date information.

**Rough-in dimensions/Overview dimensions**

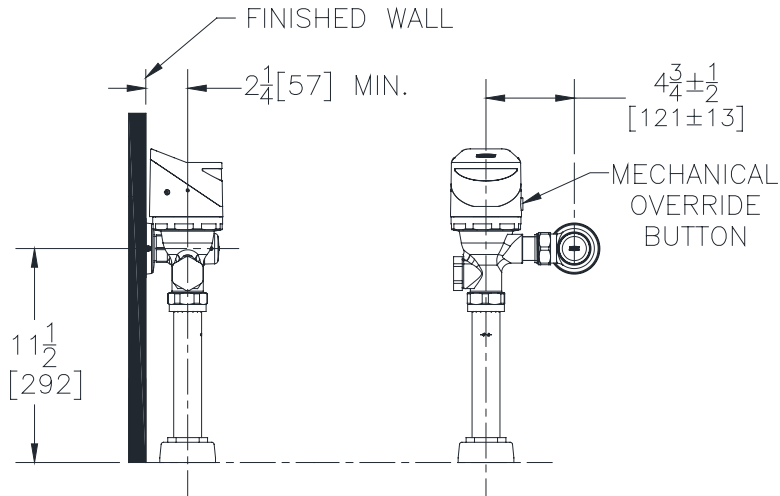

**ALTERNATE ADA INSTALLATION**

Lower water supply rough-in to 10" and mount grab bar at the 36" maximum allowed height.

