

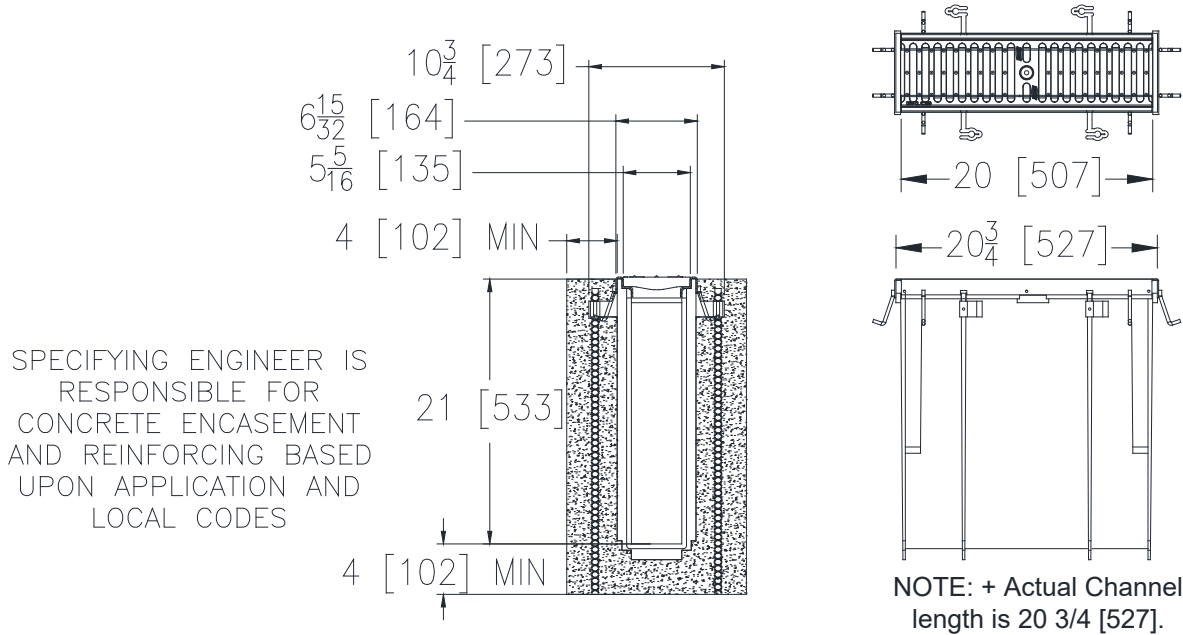

# Z887-6-HDG

## 6-7/16 [164] WIDE REVEAL X 20-3/4 [527] LONG CATCH BASIN WITH HEAVY DUTY GALVANIZED FRAME

Design and Dimensional Data (inches and [ mm ]) are Subject to Manufacturing Tolerances and Change Without Notice



SPECIFYING ENGINEER IS RESPONSIBLE FOR CONCRETE ENCASEMENT AND REINFORCING BASED UPON APPLICATION AND LOCAL CODES

**ENGINEERING SPECIFICATION:** ZURN Z887-6-HDG Catch Basin shall be 6-7/16" [164mm] wide reveal x 20-3/4" [527mm] long, and 20" [508mm] deep. The body shall be made of 0% water absorbent High Density Polyethylene (HDPE). Shall mechanically lock into the concrete surround a minimum of every 10" [254mm]. Catch basin shall weigh less than 17 lbs./ft. [25.3 kg/m]. Catch basin shall have rebar clips standard to secure basin in its final location. Shall be provided with standard GDC grates that lock down with lockdown bars to the basin and is not intended for dynamic traffic loadings. Zurn 6" [152mm] wide reveal Galvanized Ductile Iron Slotted Grate conforming to ASTM specification A536-84, Grade 80-55-06. Ductile Iron grate is rated class C per the DIN EN1433 top load classifications. Supplied in 20" [508mm] nominal lengths with 1/2" [13mm] wide slots, and 3/4" [19mm] bearing depth. Grate has an open area of 28.1 in<sup>2</sup>/ft. [603 cm<sup>2</sup>/m]. The .105" [2.66mm] thick Heavy-Duty Carbon Steel Galvanized Frame Assembly conforms to ASTM specification A36 with 4 - 4" [102mm] long concrete anchors per basin. Frame supplied with powder coated finish. All welds must be performed by a certified welder per ASTM standard AWS D1.1. Frames produced in the U.S.A.

**PREFIX OPTIONS (Check/specify appropriate options)**  
\_\_\_ Z 6" X 20" High Density Polyethylene (HDPE) Catch Basin\*

**SUFFIX OPTIONS (Check/specify appropriate options)**

- Outlet Adapters Add/Each**
- \_\_\_ -E3/U3 3 [76] No-Hub End Outlet
  - \_\_\_ -E4/U4 4 [102] No Hub End Outlet
  - \_\_\_ -E6/U6 6 [152] No-Hub End Outlet
  - \_\_\_ -IA Inlet Adapter (Z886)
  - \_\_\_ -IA Inlet Adapter (Z882)

- Miscellaneous Options**
- \_\_\_ -VP Vandal-Proof Lockdown
  - \_\_\_ -Y Sediment Bucket
  - \_\_\_ -BL High Density Polyethylene (HDPE) Catch Basin with 3% Carbon Black Additive

- USA Miscellaneous Options**
- \_\_\_ -DB Bottom Dome Strainer

\* Regularly furnished unless otherwise specified.

Frame and Grate Options on Page 2

**WARNING:** Cancer and Reproductive Harm - [www.P65Warnings.ca.gov](http://www.P65Warnings.ca.gov)  
**ADVERTENCIA:** Cáncer y daño reproductivo - [www.P65Warnings.ca.gov](http://www.P65Warnings.ca.gov)  
**AVERTISSEMENT:** Cancer et effets néfastes sur la reproduction - [www.P65Warnings.ca.gov](http://www.P65Warnings.ca.gov)



# Z887-6-HDG

6-7/16 [164] WIDE REVEAL X 20-3/4 [527] LONG CATCH  
BASIN WITH HEAVY DUTY GALVANIZED FRAME

Design and Dimensional Data (inches and [ mm ]) are Subject to Manufacturing Tolerances and Change Without Notice

**Grate Options** (Load Classifications are per DIN EN1433)

- \_\_\_ -BDC Black Acid Resistant Epoxy Coated Ductile Grate - Class C
- \_\_\_ -BDE Black Acid Resistant Epoxy Coated Ductile Grate - Class E
- \_\_\_ -BG Galvanized Ductile Iron Bar Grate - Class C
- \_\_\_ -DBG Ductile Iron Cast Bar Grate - Class C
- \_\_\_ -DC Ductile Iron Solid Cover - Class C
- \_\_\_ -DGC Ductile Iron Slotted Grate - Class C\*
- \_\_\_ -DGE Ductile Iron Slotted Grate - Class E\*
- \_\_\_ -GDC Galvanized Ductile Slotted Grate - Class C
- \_\_\_ -GDE Galvanized Ductile Slotted Grate - Class E
- \_\_\_ -GHPDE Heel-Proof Slotted Grate, Galvanized Ductile Iron - Class E
- \_\_\_ -HPDE Heel-Proof Slotted Grate, Ductile Iron - Class E
- \_\_\_ -RFGC Reinforced Slotted Galvanized Grate - Class C
- \_\_\_ -RPGC Reinforced Perforated Galvanized Grate - Class C
- \_\_\_ -RPGRC Reinforced Galvanized Perforated Reverse Punch Anti-Slip Grate - Class C

**MADE in the U.S.A.** (Load Classifications are per DIN EN 1433)

- \_\_\_ -BDE-USA Black Acid Resistant Epoxy Coated Ductile Grate -Class E
- \_\_\_ -DCE-USA Solid Cover, Dura-Coated Ductile Iron - Class E
- \_\_\_ -DGC-USA Ductile Iron Slotted Grate-Class C
- \_\_\_ -DGE-USA Ductile Iron Slotted Grate-Class E
- \_\_\_ -GDC-USA Galvanized Ductile Slotted Grate - Class C
- \_\_\_ -GDE-USA Galvanized Ductile Slotted Grate - Class E
- \_\_\_ -PPC Plastic Perforated Grate - Class C

\* Regularly furnished unless otherwise specified.

**WARNING:** Cancer and Reproductive Harm - [www.P65Warnings.ca.gov](http://www.P65Warnings.ca.gov)

**ADVERTENCIA:** Cáncer y daño reproductivo - [www.P65Warnings.ca.gov](http://www.P65Warnings.ca.gov)

**AVERTISSEMENT:** Cancer et effets néfastes sur la reproduction - [www.P65Warnings.ca.gov](http://www.P65Warnings.ca.gov)