

Z1231-EZR ADJUSTMENT INSTRUCTIONS Factory Assembly

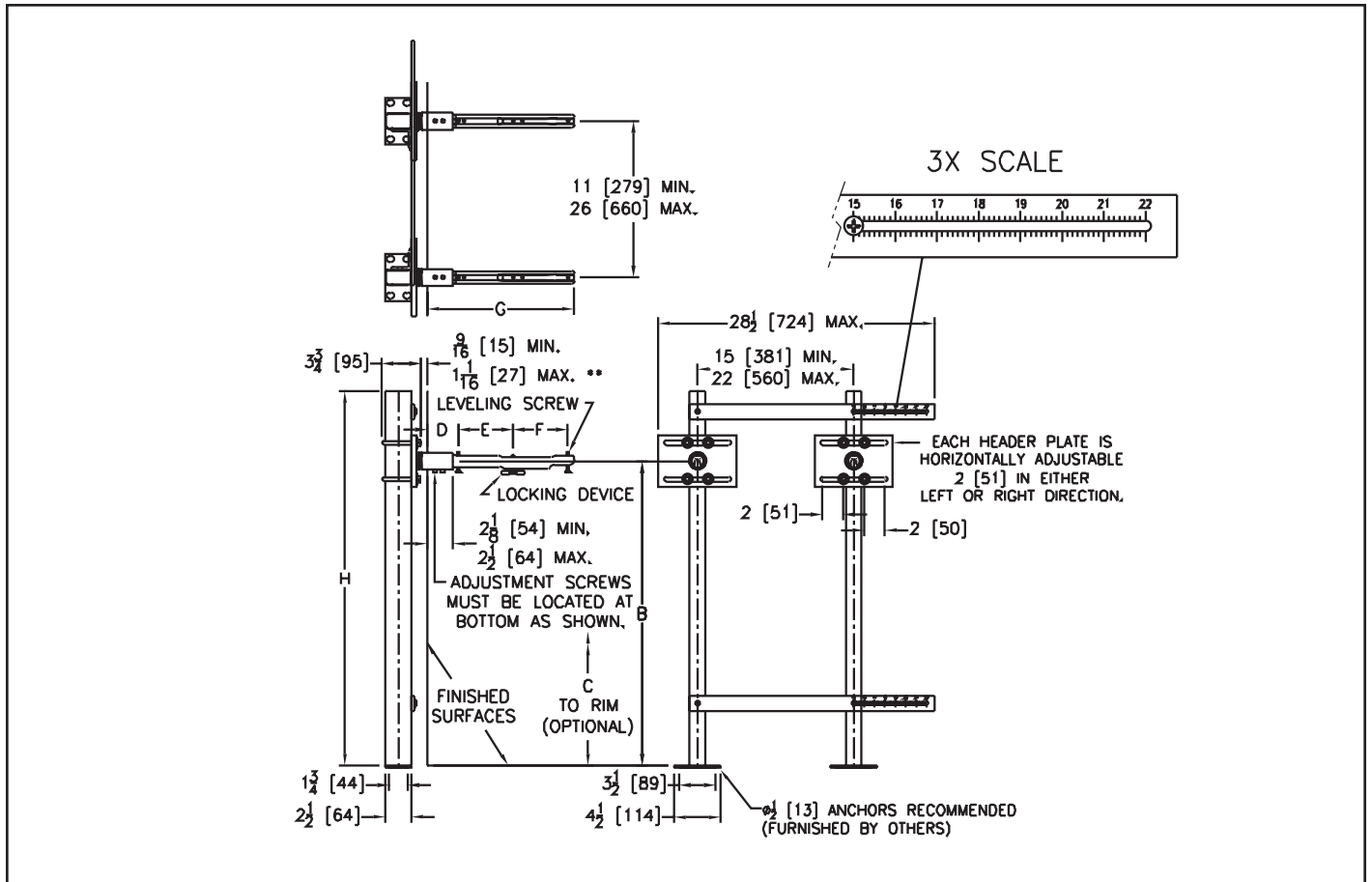

STEP 1

Refer to installation instructions in the box/bag containing the arms and sleeves to determine the appropriate dimensions for the fixture.

STEP 2

Measure from the bottom of the upright ("E") to the center of the large tapped (1-1/4" - 11-1/2" NPT) hole in the flat plate header ("C") to the set height dimension for centerline of sleeves. Tighten the nuts and U-bolts ("D") to secure flat plate headers ("C") to each upright ("E").

STEP 3

Slightly loosen the two hex head machine screws ("B") which are in the right-hand side upright at the stamped-in ruler and slot on cross bars ("A"). Make sure the bottom of the uprights ("E") are sitting on a flat surface if standing up or against an even surface if laying down, to make sure the bottoms are even. Using the stamped-in ruler on the cross bars ("A"), slide the right-hand upright ("E") to the desired location until the center of the top and bottom hex head machine screws ("B") are at the proper stamped-in ruler mark (i.e. 17-1/2, 18-1/4, etc.) for the center-to-center spacing between the uprights ("E") which will then give the sleeves and arms their correct center-to-center spacing dimensions. Tighten the two hex head machine screws ("B").

STEP 4

Recheck tightness of all U-bolts and nuts ("D") and hex head machine screws ("B").

STEP 5

Mount uprights ("E") to concrete floor using 1/2 lags (furnished by others).

⚠ **WARNING:** Cancer and Reproductive Harm - www.P65Warnings.ca.gov
 ⚠ **ADVERTENCIA:** Cáncer y daño reproductivo - www.P65Warnings.ca.gov
 ⚠ **AVERTISSEMENT:** Cancer et effets néfastes sur la reproduction - www.P65Warnings.ca.gov