



Zurn Wilkins 300ASTR Series

Backflow Preventer Order Form



375ASTR

Save time and money during backflow replacement with custom-length assembly.

Features and Benefits

- 300ASTR drop-in assembly drastically reduces installation time and building's water downtime, making it the ideal solution for retrofit and replacement installations
- Proven performance and effective repair kits ensure lowest maintenance and repair costs over entire lifecycle
- Shutoffs remain in the same location as previous installation, enabling tamper switches to be reinstalled on OS&Y shutoffs without modifying electrical wiring
- Completely assembled and shipped system with custom-length AR spool eliminates field cutting and spool assembly
- Measure and submit the current flange face-to-face dimension and your 300ASTR will be built to match the current footprint*
- All units ship in two business days and most can be supplied from one of our regional service centers for faster delivery
- Fully compliant design is approved by the Foundation for Cross Connection Control and Hydraulic Research at USC

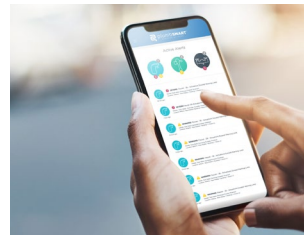

Get Connected Now With This 300ASTR Order and the Zurn Connected Pressure Monitor (ZCSM-PF)

The Zurn Connected Pressure Monitor allows you to remotely monitor your water pressure. Simply set high- and low-pressure thresholds for real-time alerts through our secure web portal, plumbSMART™. Attaches easily into any backflow preventer test cock.

System Offers:

- Proactive incoming water pressure monitoring
- Real-time alerts for preset high and low pressure

plumbSMART Delivers:

- Real-time pressure alerts update you on the water pressure from the city based on your thresholds
- Data trends on high, low and average pressure help you identify and troubleshoot potential issues
- 24/7 remote monitoring and alerts keep you in control

*Assemblies manufactured within +0/-1/4" tolerance of stated length

Zurn Wilkins 300ASTR Series Backflow Preventer Order Form

Email this Order Form with the Purchase Order to: Zurn Wilkins Customer Care, email: wilkinscs@zurn.com. Order form should also be attached to sales order in Axapta.

Part #

FACE TO FACE DIMENSIONS

Face-to-face dimension (exact field measurement, $\pm 1/16"$) of the existing backflow preventer, including shutoffs (see image to the right)*

Face to Face Dimension

Assemblies manufactured within $+0" / -1/4"$ tolerance of stated length.
Use $1/8"$ full-face rubber gaskets to make up tolerance gap. Measure twice, cut once.

OTHER DETAILS

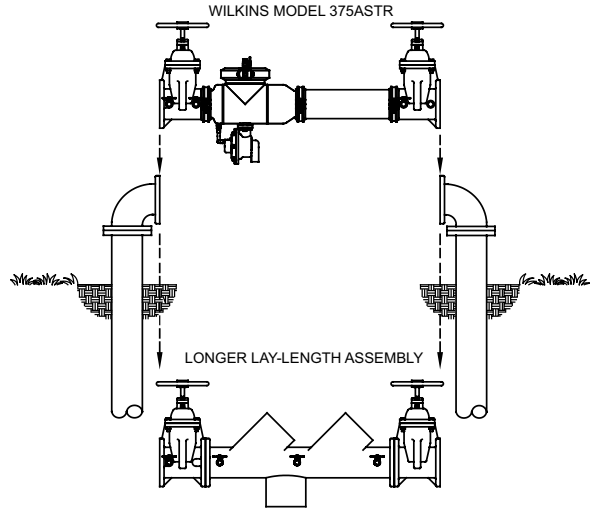

Custom lengths longer than shown are available.

*If ordered as a single part number including ancillary equipment such as wye strainers, the face-to-face length will be inclusive of that ancillary equipment. However, the components may ship separately.

VALVE SIZE	MINIMUM FACE TO FACE DIMENSIONS (OVERALL LAY LENGTH)		MAXIMUM LENGTHS
	STAINLESS STEEL BODY*		
	GATE VALVES	BUTTERFLY VALVES	
2-1/2"	34"	31"	47-1/8"
3"	35"	31-1/2"	48-1/8"
4"	37-3/8"	32-5/8"	62-1/4"
6"	46"	39"	71-1/4"
8"	55-3/4"	48-3/4"	86"
10"	58-5/8"	52-5/8"	100-5/8"

OPTIONAL

Contractor Firm

Contractor Contact

Sales Order #

Rep Agency

Rep Contact

PO #

ORDER INFORMATION

	Stainless Steel Body Standard Valve	Stainless Steel Detector Assembly	DA Meter Type		
			GPM	CFM	CMM
Double Check	350ASTR	350ASTDAR			
Reduced Pressure	375ASTR	375ASTDAR			

Size	2-1/2"	3"	4"	6"	8"	10"
------	--------	----	----	----	----	-----

Inlet Gate Valve	NRS	OS&Y	Butterfly	PI
Outlet Gate Valve	NRS	OS&Y	Butterfly	PI
Inlet End Connection	Flanged		Grooved	
Outlet End Connection	Flanged		Grooved	

GET CONNECTED NOW

ZURN CONNECTED PRESSURE MONITOR

Yes, I would like to connect my backflow with the Zurn Connected Pressure Monitor
If Yes, you must complete Gateway information below.

GATEWAY

Is there already a Zurn Gateway installed within 1000 feet of the location this product will be installed?

Yes, I already have a gateway No, I need a gateway

If gateway needed, then please select preferred mode of data transmission:

Ethernet (ZGW-LORA-WI-ETH) LTE cellular (ZGW-LORA-WI-LTE)

Contact person at site to verify gateway connectivity selection and/or cellular signal strength:

Name _____ Phone # _____

Shipping details

Zurn gateway shipped to same location (ships UPS)