

Innovation in Drainage **Z451 Shallow Trapway**

A low-profile, all-in-one solution!



Versatility

- Ideal for shallow installations including showers and balconies
- Accepts proven Z400 series strainers
- Invertible membrane clamping collar with seepage slots allows on-site customization to job specific needs

Labor Savings

- Integral trapway simplifies installation
- Eliminates the need to pierce structural decking
- Compatible with innovative floor leveling systems

Quality

- Exceeds system and trapway requirements as outlined in ASME A112.6.3 and ASTM A888
- Dura-Coated cast iron construction

Structural Deck Installation

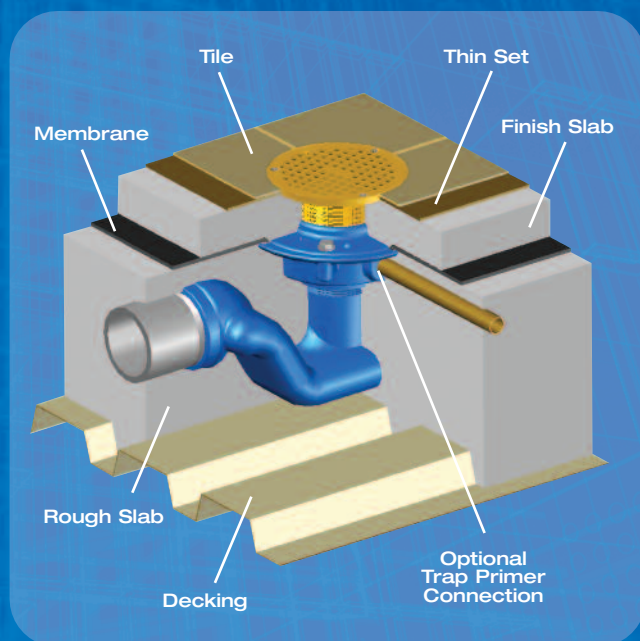

Zurn Z451B Integral Trap Shallow Floor Drain

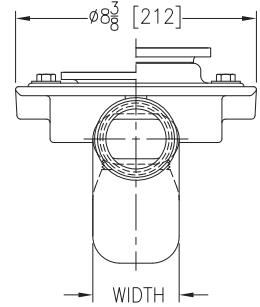
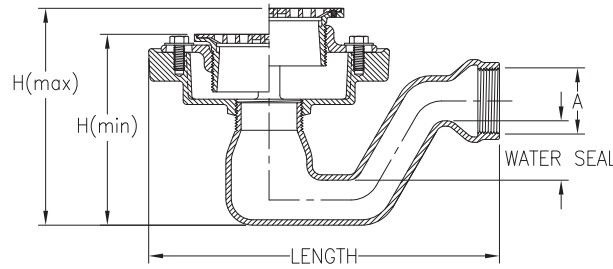

Strainer Designation	Dimensions in Inches										
	A Pipe Size	Strainer Diameter	Overall Height (2" [51] Outlet)		Overall Height (3" [76] Outlet)		Water Seal	Length	Width	Approx Weight Lbs. [kg]	Strainer Open Area Sq. In.
			Min.	Max.	Min.	Max.					
Z451-5B	2 [51]	5 [127]	7-1/8 [181]	8-3/8 [213]	8-1/4 [210]	9-1/2 [241]	2-1/16 [52]	12-3/16 [310]	3 [76]	15 [7]	8 [52]
Z451-5B	3 [76]	5 [127]	7-1/8 [181]	8-3/8 [213]	8-1/4 [210]	9-1/2 [241]	2-1/2 [64]	12-15/16 [329]	5-13/16 [148]	15 [7]	8 [52]
Z451-6B	2 [51]	6 [152]	7-1/8 [181]	8-21/32 [220]	8-1/4 [210]	9-25/32 [248]	2-1/16 [52]	12-3/16 [310]	3 [76]	18 [8]	9 [58]
Z451-6B	3 [76]	6 [152]	7-1/8 [181]	8-21/32 [220]	8-1/4 [210]	9-25/32 [248]	2-1/2 [64]	12-15/16 [329]	5-13/16 [148]	18 [8]	9 [58]
Z451-7B	2 [51]	7 [178]	7-1/8 [181]	9 [229]	8-1/4 [210]	10-1/8 [257]	2-1/16 [52]	12-3/16 [310]	3 [76]	20 [9]	12 [77]
Z451-7B	3 [76]	7 [178]	7-1/8 [181]	9 [229]	8-1/4 [210]	10-1/8 [257]	2-1/2 [64]	12-15/16 [329]	5-13/16 [148]	20 [9]	12 [77]
Z451-8B	3 [76]	8 [203]	7-9/32 [185]	9 [229]	8-13/32 [214]	10-1/8 [257]	2-1/2 [64]	12-15/16 [329]	5-13/16 [148]	21 [10]	18 [116]

ENGINEERING SPECIFICATION: ZURN ZN451B Shallow trap floor and shower drain, Dura-Coated cast iron body with bottom outlet, combination invertible membrane clamp and adjustable collar with seepage slots, adjustable TYPE B polished, nickel bronze heel-proof strainer and cast iron shallow trap body with 2" or 3" [51 or 76] waterway and threaded side outlet.

Z451B Options

OUTLETS (Specify pipe size in inches and type of outlet.)

Outlet Type	DESIGNATION Pipe Size/Outlet Type
Threaded	2IP
Threaded	3IP

PREFIXES

- ZB** D.C.C.I. Body Assembly w/ Polished Bronze Top
- ZN** D.C.C.I. Body Assembly w/ Polished Nickel Bronze Top*
- * Regularly furnished unless otherwise specified

SUFFIXES

- AR** Acid Resisting Epoxy Coated Cast Iron
- CP** Chrome-Plated Top
- DC** Debris Cover
- DP** Decorative Polished Top
- G** Galvanized Cast Iron
- HD** Heavy-Duty Slotted Grate (ZN Only)
- P** Trap Prime Connection (Specify 1/2" [13] or 3/4" [19])
- U** 1"-3" [26-76] High Extension Adapter
- V** Backwater Valve
- VP** Vandal-Proof Secured Top
- Y** Sediment Bucket
- 18** Leveling Ring (See Z400-18)

Available Strainers Include:

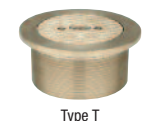
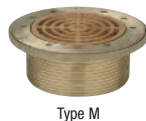
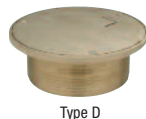

ZURN INDUSTRIES, LLC SPECIFICATION DRAINAGE OPERATION
 1801 PITTSBURGH AVENUE, ERIE, PA, U.S.A. 16502, PHONE: 855-ONE-ZURN (855-663-9876), FAX: 814-454-7929 www.zurn.com
 In Canada: **ZURN INDUSTRIES LIMITED**
 3544 NASHUA DRIVE, MISSISSAUGA, ONTARIO L4V 1L2, PHONE: 905-405-8272, FAX: 905-405-1292