

ZURN Light Commercial

RD2190 Universal Membrane Clamp

The RD2190 is designed for retrofit roof applications where the existing main roof drain is to be utilized. The tie-down lugs of the collar match the bolt pattern of the more common roof drain bodies and conform to the surface angles of the flange, allowing timely replacement along with desirable surface pressure on the membrane. The universal Dura-Coated cast iron membrane clamp device (UMC), is designed to accompany most 12" and 16" diameter roof drain bodies with accessory bolt circles ranging from 8" to 10 -1/2" in diameter. Note: When using RD2190 UMC, it is advisable to extend roof membrane into the sump of the existing roof drain body.



ZURN INDUSTRIES, LLC
LIGHT COMMERCIAL OPERATION
1801 PITTSBURGH AVENUE, ERIE, PA, U.S.A. 16502
PHONE: 885-ONE-ZURN (855-663-9876)
FAX: 814/875-1402
www.zurn.com

RD2190 Universal Membrane Clamp

For Retrofit Roof Applications

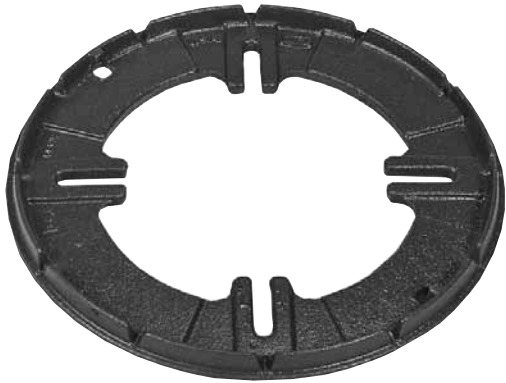

Options

- DS Dura-Coated Cast Iron Dome Strainer
- VP Vandal-Proof Screws for Dome

The RD2190 UMC Standard Assembly Consists of

- (1) Cast Iron UMC
- (4) 3/8-16" x 1-3/4" [45mm] Hex Head Bolts
- (4) 3/6-16" x 1-1/4" [32mm] Hex Head Bolts
- (4) 5/16-18" x 1-1/4" [32mm] Hex Head Bolts
- (4) 3/8-16" x 4" [102mm] Studs
- (4) 3/8" Nuts
- (4) 3/8" Washers

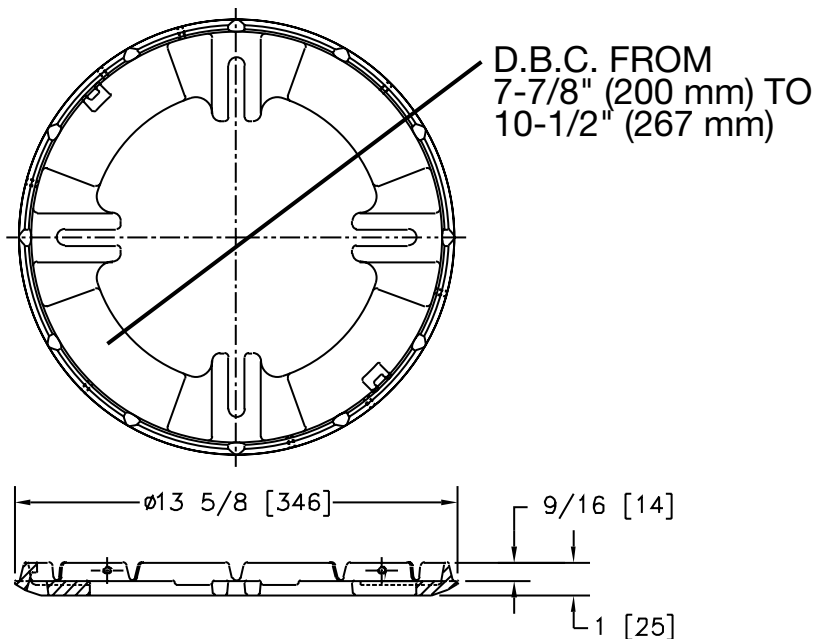

ZURN INDUSTRIES, LLC LIGHT COMMERCIAL OPERATION
1801 PITTSBURGH AVENUE, ERIE, PA, U.S.A. 16502
PHONE: 885-ONE-ZURN (855-663-9876) FAX: 814/875-1402 www.zurn.com