



GENERAL PRODUCT ILLUSTRATION

Z1203-XH, Z1204-XH

EXTRA HEAVY-DUTY WATER CLOSET SYSTEMS

Dimensional Data (inches and [mm]) are Subject to Manufacturing Tolerances and Change Without Notice

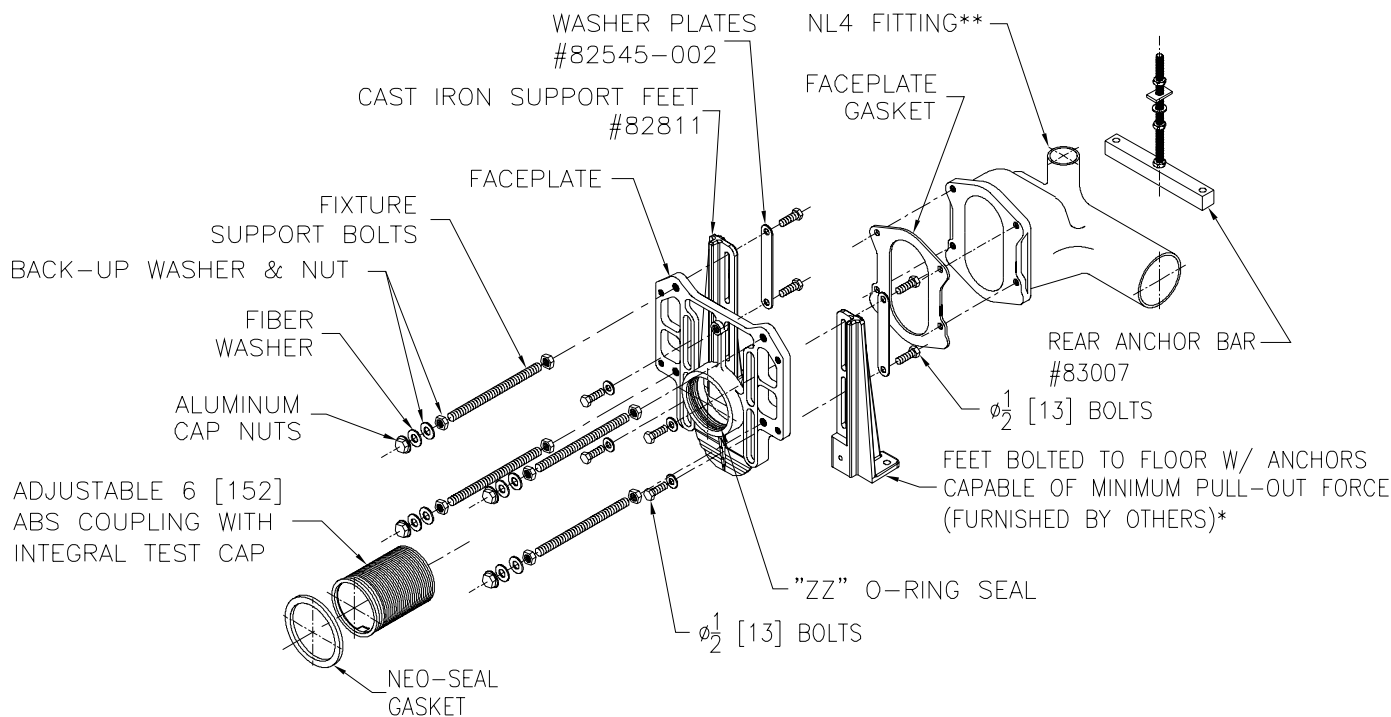

*Carrier foot anchors must be able to withstand a pull-out force of 271 Lb.[123 kg.]. Calculated value, no safety factor applied.

**Horizontal fitting shown. Vertical fittings also available.

Z1203-XH, Z1204-XH EXTRA HEAVY-DUTY WATER CLOSET SYSTEM

Offers:

1. All Dura-Coated cast iron construction with 750 lb. [340 Kg.] load bearing capability to A.N.S.I. A112.6.1M
2. Vertical adjustment of 4-1/2 [114] to 9-1/2 [241] for Siphon-Jet closet installation. System accommodates for both paraplegic and standard rough in requirements.
3. 11 1/16 [281] required from finished wall to back of system for Z1203-N4-XH and Z1204-N4-XH, 12 5/16 [313] required for Z1204-N5-XH and 13 5/16 [338] required for Z1204-N6-XH.
4. Non-corrosive ABS adjustable coupling with integral test cap and unique 'ZZ' Zurn adjusting thread.

Form # C34

Date: 04/24/07

C.N. No. 96511

Rev.

ZURN INDUSTRIES, LLC ♦ SPECIFICATION DRAINAGE OPERATION ♦ 1801 Pittsburgh Ave. ♦ Erie, PA 16514
Phone: 814/455-0921 ♦ Fax: 814/454-7929 ♦ World Wide Web: www.zurn.com

In Canada: ZURN INDUSTRIES LIMITED ♦ 3544 Nashua Drive ♦ Mississauga, Ontario L4V1L2 ♦ Phone: 905/405-8272 Fax: 905/405-1292