

# AQUASPEC<sup>®</sup> FAUCETS

MODEL - Z86700-XL SERIES  
WIDESPREAD METERING



## TECHNICAL INFORMATION

**FLOW:** 0.25 GPC MAXIMUM; PRESET AT FACTORY TO 10 TO 15 SECONDS @ 80 PSI ADJUSTABLE  
**MAXIMUM PRESSURE:** 80 PSI  
**MAXIMUM TEMPERATURE:** 140° F

**IMPORTANT THE WATER SUPPLY LINES MUST BE THOROUGHLY FLUSHED BEFORE INSTALLATION TO PREVENT FOREIGN MATTER AND DEBRIS FROM CLOGGING AND/OR DAMAGING INTERNAL COMPONENTS**

**IMPORTANT THE FAUCET HAS AN INTEGRAL SHANK FILTER ASSEMBLY INSTALLED IN THE BODY UNDER THE METERING CARTRIDGE TO PREVENT FOREIGN MATTER AND DEBRIS FROM DAMAGING THE FAUCET. THE INTEGRAL FILTER MAY BE REMOVED TO BE BACK-FLUSHED AND CLEANED IF INSUFFICIENT FLOW IS DETECTED. THE INTEGRAL SHANK FILTER ASSEMBLY MUST BE RE-INSTALLED AFTER SERVICING TO ENSURE PROPER FUNCTIONING OF THE METERING CARTRIDGE.**

⚠ **WARNING:** Cancer and Reproductive Harm - [www.P65Warnings.ca.gov](http://www.P65Warnings.ca.gov)

⚠ **ADVERTENCIA:** Cáncer y daño reproductivo - [www.P65Warnings.ca.gov](http://www.P65Warnings.ca.gov)

⚠ **AVERTISSEMENT:** Cancer et effets néfastes sur la reproduction - [www.P65Warnings.ca.gov](http://www.P65Warnings.ca.gov)

## \* INSTALLATION INSTRUCTIONS

1. THE WATER SUPPLY LINES MUST BE THOROUGHLY FLUSHED BEFORE FAUCET INSTALLATION.
2. PLACE RUBBER GASKET (#7D) ONTO SHANK OF SPOUT BASE (#5). PLACE SHANK THROUGH CENTER HOLE OF SINK AND SECURE USING WASHER (#7E), LOCK WASHER (#7F) AND MOUNTING NUT (#7G). DO NOT OVER TIGHTEN.
3. REMOVE BODY (ITEMS #8, #9 & #10) FROM PACKAGING. SCREW FLANGED MOUNTING NUT (#9A) ALL THE WAY DOWN ONTO BODY (#9).
4. REMOVE ADJUSTMENT NUT (#2E) FROM HANDLE NUT ASSEMBLY (#2).
5. INSTALL BODY ASSEMBLY (#9) BY INSERTING UP THROUGH SINK DECK. INSTALL "E" RETAINING RING (#7A) INTO GROOVE ON BODY (#9) TO ALLOW BODY TO "HANG" THROUGH HOLE IN SINK DECK. REPEAT FOR BOTH HOT AND COLD SIDES.
6. TIGHTEN MOUNTING NUT (#9A) AGAINST "E" RETAINING RING (#7A) FROM UNDER SINK DECK TO CREATE A SECURE CONNECTION.
7. INSTALL THREADED ESCUTCHEON (#6) ONTO HANDLE NUT CAP (#2F). HAND TIGHTEN.
8. REPLACE ADJUSTMENT NUT (#2E) ONTO HANDLE NUT ASSEMBLY (#2).
9. PLACE GASKET (#8A) BETWEEN TEE (#8D) AND SHANK. SECURE TEE TO SHANK WITH NUT (#8C).
10. THIS STEP IS ONLY NECESSARY FOR FAUCETS WITH SEPARATE SPOUT/BASE ASSEMBLIES. INSTALL SPOUT INTO BASE (#5) AND TIGHTEN SPOUT NUT (SEE ASSEMBLY VIEW FOR SWING/RIGID CONNECTION).
11. INSTALL FLEXIBLE SUPPLY LINE (#10) BETWEEN BODY (#9) AND TEE (#8D). USE WRENCH TO CREATE WATER TIGHT CONNECTIONS. DO NOT OVER TIGHTEN.
12. ATTACH LAVATORY SUPPLY TO INLET OF THE BODY (#9).
13. REMOVE MAINTENANCE TAG FROM SPOUT END AND ATTACH TO SHANK OF FAUCET UNDER SINK FOR FUTURE REFERENCE. \*

\* 

Remove this tag and place on supply line

INSTRUCTION GUIDELINES

- 1) Flush supply lines thoroughly before installing faucet.
- 2) Install 1.0 or 0.5 GPM spray outlet only, hand tighten.
- 3) See under handle for run time adjustment.

Need Help? 1-800-997-3876 or visit [www.zurn.com](http://www.zurn.com)

(SEE OTHER SIDE FOR ADDITIONAL INSTRUCTIONS)

 Remove this tag and place on supply line

FILTER REPLACEMENT

- 1) Remove handle and cartridge
- 2) Remove filter with 1/4" Allen wrench
- 3) Replace or clean filter, re-install filter
- 4) Install cartridge and handle

(SEE OTHER SIDE FOR ADDITIONAL INSTRUCTIONS)

14. OPTIONAL: INSTALL POP-UP (-P), GRID STRAINER (-G), AND HANDICAP OFFSET GRID DRAIN (-GH) IN SINK OUTLET AND PLUMB WASTE CONNECTION.
15. TURN SUPPLY WATER ON AND OPERATE FAUCET WHILE CHECKING FOR LEAKS.
16. CHECK CYCLE TIME WITH THE HANDLE INSTALLED USING THE "ADJUSTING THE CYCLE TIME" INSTRUCTIONS BELOW. A 10 SECOND MINIMUM CYCLE IS RECOMMENDED PER ADA GUIDELINES.
17. SECURE HANDLE ASSEMBLY (#1) BY PRESSING DOWN ON HANDLE (#1A, #1B) TO SEAT ON STEM (#2D) WHILE TIGHTENING SET SCREW (#1C) WITH 3/32" ALLEN WRENCH. PULL UP ON HANDLE TO CHECK FOR TIGHTNESS.
18. INSTALL COLOR CODED INDEX (#1D) BY PRESSING INTO SET SCREW HOLE IN HANDLE (#1B)
19. INSTALL AERATOR (#12) ONTO SPOUT END AND HAND TIGHTEN TO CREATE SEAL.

## MAINTENANCE

---

1. YOUR ZURN AQUASPEC FAUCET HAS A HIGHLY POLISHED NICKEL CHROME PLATED FINISH. CLEAN WITH SOAP AND WATER OR A MILD CLEANER WHICH IS SAFE FOR CHROME PLATING. DO NOT USE ACIDS OR TOILET BOWL CLEANER AS THEY WILL DAMAGE THE FINISH.
2. METERING CARTRIDGE (#3) REMOVAL AND REPLACEMENT.
  - 2.1. REMOVE COLORED INDEX BUTTON (#1D) FROM HANDLE (#1A).
  - 2.2. LOOSEN SET SCREW (#1C) IN HANDLE WITH 3/32" ALLEN WRENCH.
  - 2.3. PULL UP ON HANDLE TO REMOVE FROM STEM (#2C) OF HANDLE NUT ASSEMBLY (#2).
  - 2.4. REMOVE HANDLE NUT ASSEMBLY (#2) USING 1-1/8" HEX 6-POINT SOCKET.
  - 2.5. REMOVE METERING CARTRIDGE (#3) BY LIFTING OUT OF FAUCET BODY (#9). IT MAY BE NECESSARY TO OPEN THE SUPPLY STOP SLIGHTLY TO ALLOW WATER PRESSURE TO PUSH THE METERING CARTRIDGE UPWARD.
  - 2.6. INSPECT METERING CARTRIDGE (#3) FOR WORN PARTS, DAMAGED PARTS AND ANY CONTAMINATION THAT MAY BE PREVENTING THE METERING CARTRIDGE FROM MOVING FREELY OR SEATING. OTHER THAN CLEANING ANY TRAPPED DEBRIS, **THERE ARE NO SERVICEABLE PARTS IN THE METERING CARTRIDGE**. CONTAMINATED OR DAMAGED METERING CARTRIDGE ASSEMBLIES SHOULD BE REPLACED.
  - 2.7. REVERSE STEPS 2.1 THROUGH 2.5 FOR RE-ASSEMBLY. TIGHTEN CAP (#2F) WITH 1-1/8" HEX 6-POINT SOCKET UNTIL NO WATER IS LEAKING FROM UNDER THE HANDLE NUT ASSEMBLY WHEN THE FAUCET IS RUNNING. HOLD DOWN HANDLE (#1) WHILE TIGHTENING SET SCREW (#1C) TO ENSURE PROPER SEATING.
3. IT MAY BE NECESSARY TO REPLACE OR BACK FLUSH THE INTEGRAL SHANK FILTER CARTRIDGE AND AERATOR PERIODICALLY TO REMOVE COLLECTED SEDIMENT AND DEBRIS.
  - 3.1 THE INTEGRAL SHANK FILTER (#4) MAY BE REMOVED BY USING A 1/4" ALLEN WRENCH. CLEAN OR REPLACE AS REQUIRED.

## ADJUSTING THE CYCLE TIME

---

1. METERING FAUCETS ARE FACTORY PRESET FOR A 10 TO 15 SEC. CYCLE AT 80 PSI.
2. ACTUATE FAUCET 3 TO 5 TIMES TO REMOVE ANY TRAPPED AIR IN THE SUPPLY LINE OR FAUCET.
3. REMOVE HANDLE (#1) PER INSTRUCTIONS IN MAINTENANCE SECTION 2.1 THROUGH 2.3 TO EXPOSE ADJUSTMENT NUT (#2E).
4. INCREASE CYCLE TIME BY TIGHTENING ADJUSTMENT NUT (#2E) 1/2 TURN CLOCKWISE. DECREASE CYCLE TIME BY LOOSENING ADJUSTMENT NUT 1/2 TURN COUNTERCLOCKWISE. CHECK FOR DESIRED CYCLE TIME BY ACTUATING FAUCET WITH HANDLE (#1) IN PLACE ON STEM (#2C).

## REPLACEMENT PARTS

---

HANDLE NUT ASSEMBLY	G60561
METERING CARTRIDGE ASSEMBLY	G61754
HANDLE ASSEMBLY	G60522
INTEGRAL SHANK FILTER ASSEMBLY	G68020

- \* Installation Instructions are revised frequently.  
Please access website for the latest revision.

# Z867B0-XL PICTURED

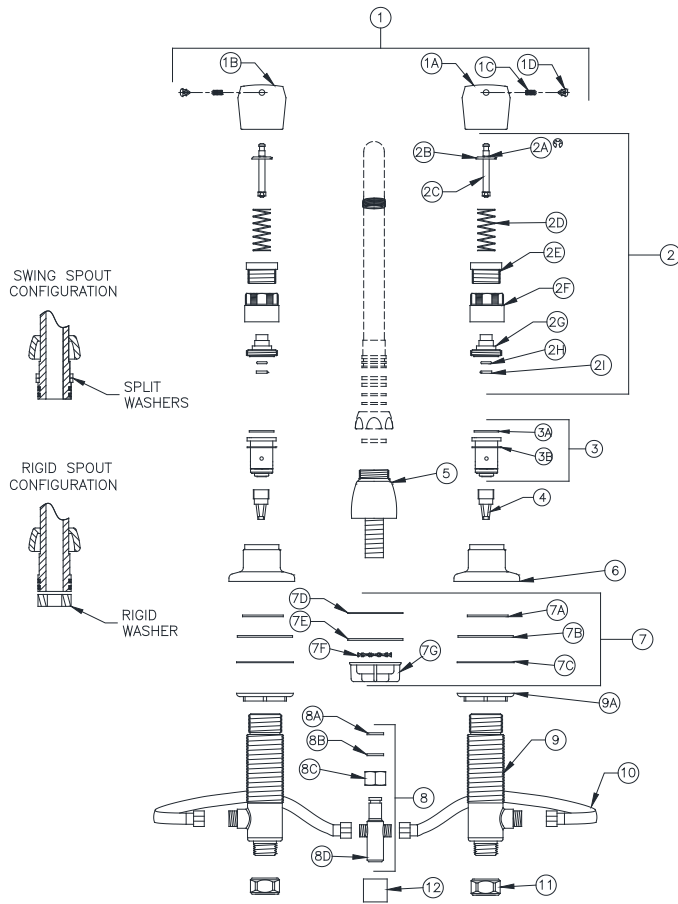

Item	Part Number	Description	Qty.	Item	Part Number	Description	Qty.
1	G61830	Metering Handle Assembly	1	6	60816001	Escutcheon	2
1A	60601002	Cold Metering Handle	1	7	G61859	Mounting Hardware Bag	1
1B	60601001	Hot Metering Handle	1	7A	60383002	"E" Retaining Ring	2
1C	62705001	Set Screw	2	7B	60382001	Stainless Steel Washer	2
1D	G60562	Metering Index Buttons - H, C	1	7C	60444001	Brass Washer	2
	60460001	Hot Index	1	7D	60148001	Rubber Gasket	1
	60460002	Cold Index	1	7E	65340001	Washer	1
2	G60561	Handle Nut Assembly	1	7F	61613019	Lockwasher	1
2A	-	E-Ring	1	7G	59530003	Flanged Mounting Nut	1
2B	-	Spring Seat	1	8	G67898	Tee Assembly	1
2C	-	Stem	1	8A	60455001	Gasket	1
2D	-	Spring	1	8B	63982001	Retaining Ring	1
2E	-	Adjustment Nut	1	8C	60145002	Shank Nut	1
2F	-	Cap	1	8D	61283005	Tee	1
2G	-	Stem Housing	1	9	93039001	Single Body Assembly	2
2H	-	O-Ring	1	9A	60445001	Widespread Nut	1
2I	-	O-Ring Retainer	1	10	93317332	Flex Hose	2
3	G61754	Metering Cartridge Assembly	2	11	59532001	1/2" Npsm Riser Nut	2
4	G68020	Integral Shank Filter	1	12	G66696	3/4"-27 Female Spray Outlet - 1.0 Gpm	1
5	G67871	Base Assembly	1				

# Z867B0-XL-P PICTURED

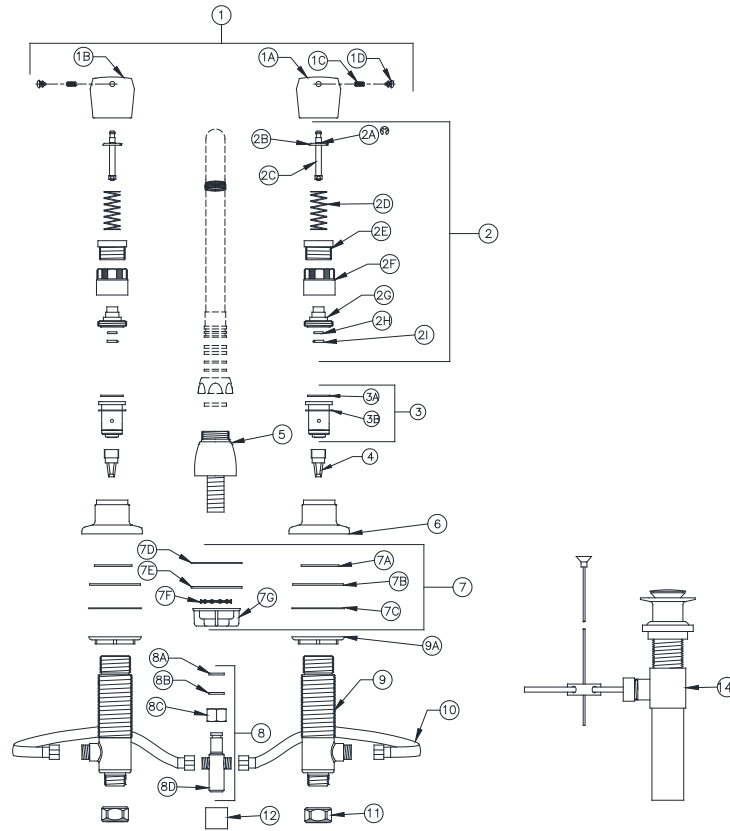

Item	Part Number	Description	Qty.	Item	Part Number	Description	Qty.
1	G61830	Metering Handle Assembly	1	7	G61859	Mounting Hardware Bag	1
1A	60601002	Cold Metering Handle	1	7A	60383002	"E" Retaining Ring	2
1B	60601001	Hot Metering Handle	1	7B	60382001	Stainless Steel Washer	2
1C	62705001	Set Screw	2	7C	60444001	Brass Washer	2
1D	G60562	Metering Index Buttons - H, C	1	7D	60148001	Rubber Gasket	1
	60460001	Hot Index	1	7E	65340001	Washer	1
	60460002	Cold Index	1	7F	61613019	Lockwasher	1
2	G60561	Handle Nut Assembly	1	7G	59530003	Flanged Mounting Nut	1
2A	-	E-Ring	1	8	G67898	Tee Assembly	1
2B	-	Spring Seat	1	8A	60455001	Gasket	1
2C	-	Stem	1	8B	63982001	Retaining Ring	1
2D	-	Spring	1	8C	60145002	Shank Nut	1
2E	-	Adjustment Nut	1	8D	61283005	Tee	1
2F	-	Cap	1	9	93039001	Single Body Assembly	2
2G	-	Stem Housing	1	9A	60445001	Widespread Nut	1
2H	-	O-Ring	1	10	93317332	Flex Hose	2
2I	-	O-Ring Retainer	1	11	59532001	1/2" Npsm Riser Nut	2
3	G61754	Metering Cartridge Assembly	2	12	G66696	3/4"-27 Female Spray Outlet - 1.0 Gpm	1
4	G68020	Integral Shank Filter	1	13	60505001	Pop-Up Drain Assembly	1
5	G67871	Base Assembly	1				
6	60816001	Escutcheon	2				

## METERING FAUCET TROUBLE SHOOTING GUIDE

<b>PROBLEM</b>	<b>CAUSE</b>	<b>SOLUTION</b>
No water dispensing from faucet.	Supply stops not open.	Open supply stops.
	Aerator (item 12) contaminated.	Remove aerator (item 12) to clean and/or replace.
	Filter assembly (item 4) contaminated.	Shut off water supply. Remove filter assembly to clean and/or replace. Filter located internally within faucet body under metering cartridge.
Faucet is shutting off too quickly.	Adjustment nut (item 2E) requires adjustment.	Remove handle (item 1) using 3/32" Allen wrench. Rotate adjustment nut (item 2E) down (CW) to lengthen handle stroke and increase cycle time.
	Metering cartridge (item #3) is damaged.	Replace metering cartridge (item 3) G61754 per Installation and Maintenance guide, page 2
Faucet is running too long or will not shut off.	Adjustment nut (item 2E) requires adjustment.	Remove handle (item 1) using 3/32" Allen wrench. Rotate adjustment nut (item 2E) up (CCW) to shorten handle stroke and decrease cycle time.
	Metering cartridge (item 3) is overly contaminated or damaged.	Replace metering cartridge (item 3) G61754 per Installation and Maintenance guide, page 2
	Aerator (item 12) is not installed or incorrect aerator (item 12) installed.	Install 1.0 GPM or 0.5 GPM aerator (item 12). Faucet may not shut off with flow rate > 1.0 GPM.
	Handle nut (item 2) is not adequately tightened.	Tighten handle nut (item 2) using 1-1/8" hex 6 point socket to create seal and seat metering cartridge. Do not over tighten.