



# Connected AquaSense® Battery Powered Flush Valve ZER-W2 Series Installation, Operation, Maintenance and Parts Manual



**ZER6000AV-W2**



**ZER6003AV-W2**

- ⚠ **WARNING:** Cancer and Reproductive Harm - [www.P65Warnings.ca.gov](http://www.P65Warnings.ca.gov)
- ⚠ **ADVERTENCIA:** Cáncer y daño reproductivo - [www.P65Warnings.ca.gov](http://www.P65Warnings.ca.gov)
- ⚠ **AVERTISSEMENT:** Cancer et effets néfastes sur la reproduction - [www.P65Warnings.ca.gov](http://www.P65Warnings.ca.gov)

#### LIMITED WARRANTY

All goods sold hereunder are warranted to be free from defects in material and factory workmanship for a period of three years from the date of purchase. Decorative finishes warranted for one year. We will replace at no costs goods that prove defective provided we are notified in writing of such defect and the goods are returned to us prepaid at Sanford, NC, with evidence that they have been properly maintained and used in accordance with instructions. We shall not be responsible for any labor charges or any loss, injury or damages whatsoever, including incidental or consequential damages. The sole and exclusive remedy shall be limited to the replacement of the defective goods. Before installation and use, the purchaser shall determine the suitability of the product for his intended use and the purchaser assumes all risk and liability whatever in connection therewith. Where permitted by law, the implied warranty of merchantability is expressly excluded. If the products sold hereunder are "consumer products," the implied warranty of merchantability is limited to a period of three years and shall be limited solely to the replacement of the defective goods. All weights stated in our catalogs and lists are approximate and are not guaranteed.



## **Electronic emission notices**

This device complies with Part 15 of the FCC Rules. Operation is subject to the following two conditions: (1) this device may not cause harmful interference, and (2) this device must accept any interference received, including interference that may cause undesired operation.

The following information refers to Zurn Smart Connected Products, types: -W1. This equipment has been tested and found to comply with the limits for a Class A digital device, pursuant to Part 15 of the FCC Rules. These limits are designed to provide reasonable protection against harmful interference intended for use in non-residential/non-domestic environments. This equipment generates, uses, and can radiate radio frequency energy and, if not installed and used in accordance with the instructions, may cause harmful interference to radio communications. However, there is no guarantee that interference will not occur in a particular installation. If this equipment does cause harmful interference to radio or television reception, which can be determined by turning the equipment off and on, the user is encouraged to try to correct the interference by one or more of the following measures:

- Reorient or relocate the receiving antenna.
- Increase the separation between the equipment and receiver.
- Connect the equipment into an outlet on a circuit different from that to which the receiver is connected.
- Consult an authorized dealer or service representative for help.

Zurn is not responsible for any radio or television interference caused by using other than specified or recommended cables and connectors or by unauthorized changes or modifications to this equipment. Unauthorized changes or modifications could void the user's authority to operate the equipment.

Responsible party: ZURN INDUSTRIES, LLC 511 W. Freshwater Way, Milwaukee, WI  
U.S.A. 53204 · Ph. 1-855-ONE-ZURN, Fax 919-775-3541

## Prior to Installation

Prior to installing the ZER Flushometer, install the items listed below:

- Closet or urinal fixture
- Drain line
- Water supply line

### IMPORTANT:

- ALL PLUMBING IS TO BE INSTALLED IN ACCORDANCE WITH APPLICABLE CODES AND REGULATIONS.
- WATER SUPPLY LINES MUST BE SIZED TO PROVIDE AN ADEQUATE VOLUME OF WATER FOR EACH FIXTURE.
- FLUSH ALL WATER LINES PRIOR TO OPERATION (See Step 9).
- DIRT AND DEBRIS CAN CAUSE FLUSH VALVE TO RUN CONTINUOUSLY.

## Sweat Solder Adapter Installation Instructions

**NOTE:** Before installation, turn off water supplies to existing fixture and remove flushometer if replacing an existing device.

1. Measure distance from finished wall to the center line of the fixture spud. If necessary, cut water supply pipe 1-1/4" shorter than this measurement. Deburr by chamfering O.D. and I.D. of end of water supply pipe.

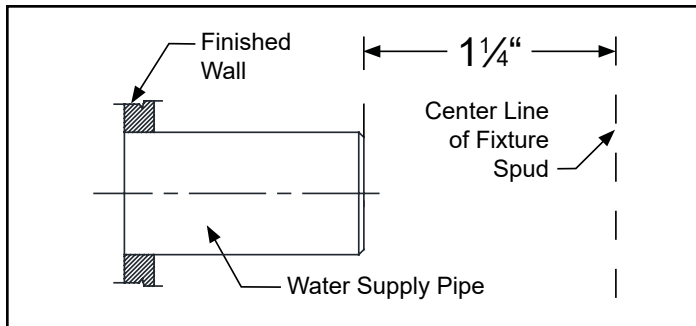

2. Slide threaded sweat solder adapter onto water supply pipe until shoulder stops on end of pipe. Then sweat-solder the adapter to water supply pipe.

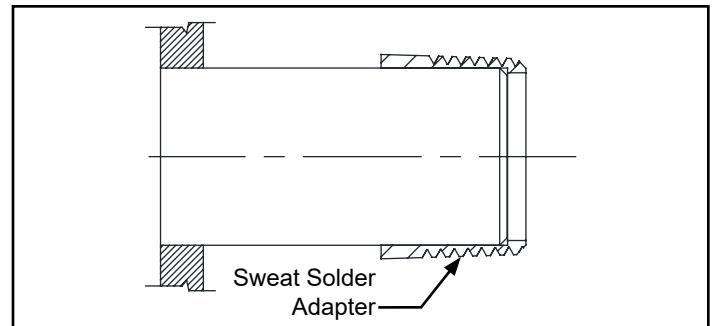

3. Measure distance from finished wall to first thread of sweat solder adapter. If necessary, cut chrome cover tube this length.

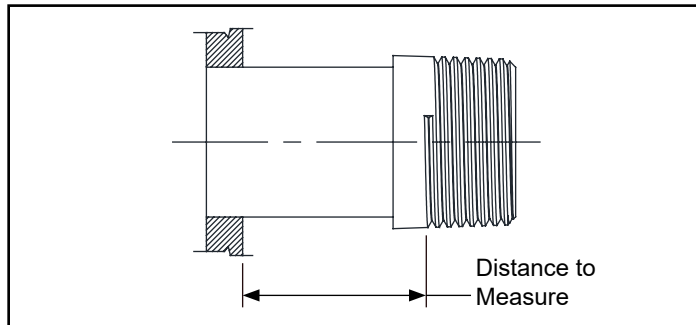

4. Slide wall escutcheon over chrome cover tube and slide both items over water supply pipe. Press wall escutcheon flush against finished wall and tighten set screw with hex wrench (supplied) to secure it in place.

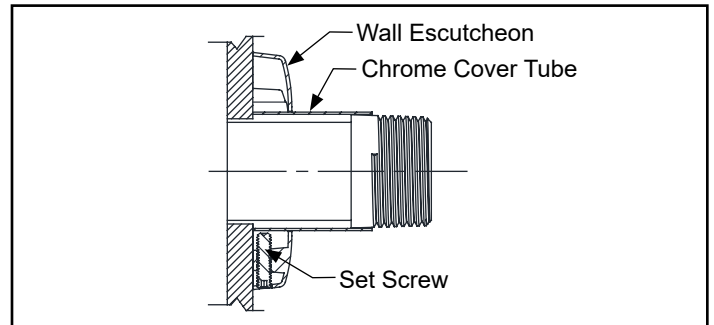

## Control Stop Installation Instructions

1. Install control stop assembly by threading it onto water supply pipe and tightening with a smooth jawed wrench. Apply thread sealing compound or pipe tape to male NPT thread on sweat solder adapter only. Prior to turning on main water supply line ensure all stop valves are closed off tight by using a flathead screwdriver and turning the stop valve adjustment screw clockwise.

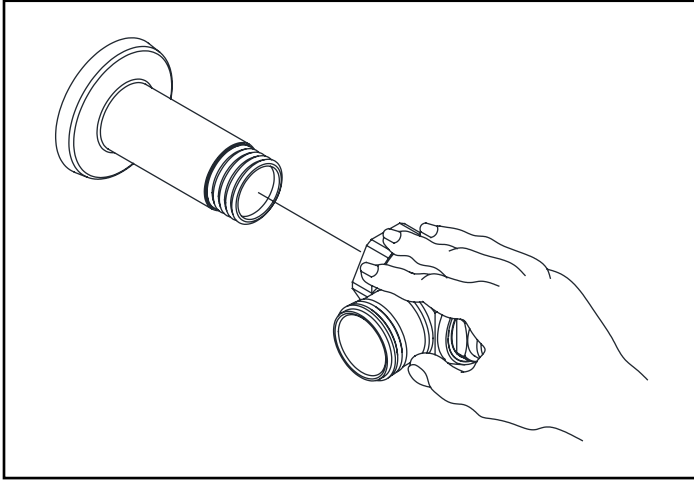

2. When all stop valves are properly connected to the water supply line and water pressure is available, open the control stop using a flat head screwdriver and turning the stop valve adjustment screw counterclockwise. Allow the water supply line to flush any debris or sediment that may be present in the line. Close the control stop once the lines are completely flushed.

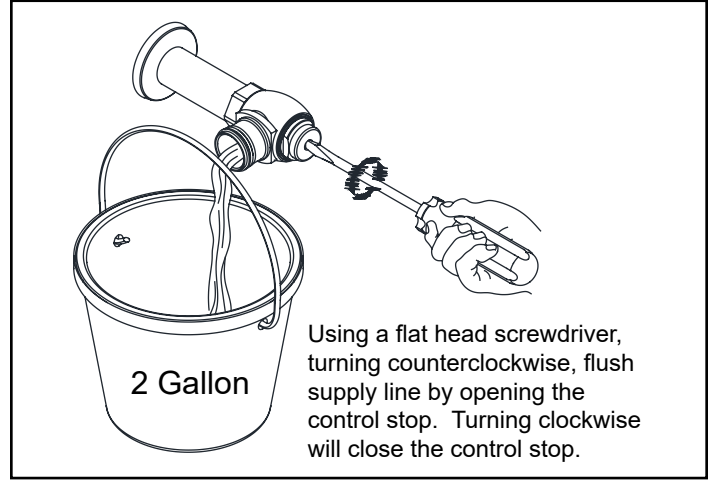

## Flush Valve Installation Instructions

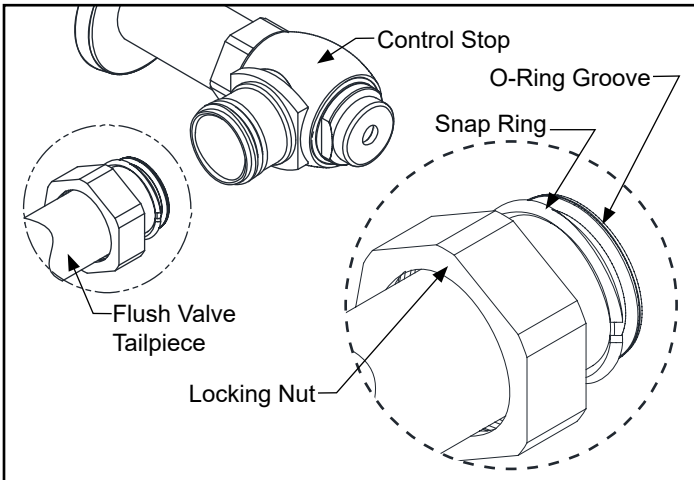

- Prior to attaching flush valve tailpiece to control stop, inspect and verify that the O-ring seal is located within the O-ring groove at the tailpiece. Ensure that the locking nut and locking snap ring are also present on the tailpiece.

Lubricate O-ring with water if necessary and insert flush valve tailpiece into the control stop valve. Tighten locking nut using a smooth jawed wrench.

## Vacuum Breaker & Flush Connection Installation Instructions

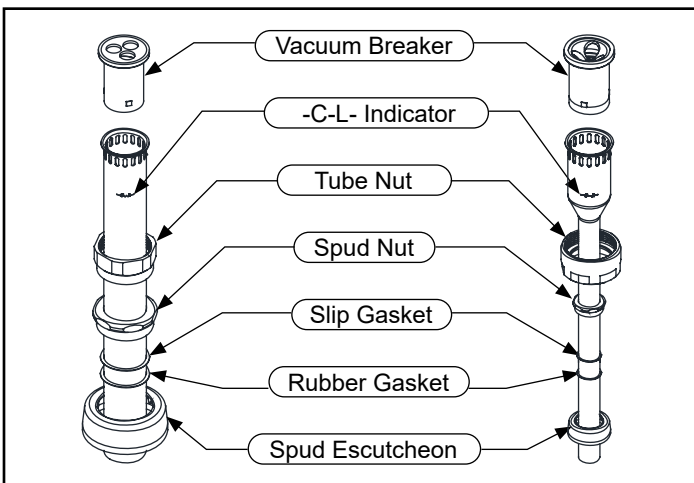

- Determine the length of vacuum breaker tube required to join the flush valve and fixture spud, and cut if necessary.

Slide the tube nut, spud nut, slip gasket, rubber gasket and spud escutcheon over the vacuum breaker tube and insert tube into fixture spud. Hand tighten tube nut to valve body and hand tighten spud nut onto fixture spud. Adjust the valve assembly for plumb. Tighten fixture spud nut, vacuum breaker tube nut and locking nut with a wrench.

Adjust and plumb the valve assembly. Tighten all connections with smooth jawed wrench and turn on water supply at the control stop.

**⚠ DO NOT** cut vacuum breaker tube shorter than 6" below the -C-L- indicator mark, as vacuum breaker must be 6" above the fixture. Consult plumbing Codes & Regulations for specific details.

## Flush Valve Activation

Using supplied battery compartment wrench, remove battery compartment from the E-Z Flush™ unit.

Load batteries into compartment tray (note position of batteries in tray), and reinstall battery tray into the E-Z Flush unit.

Secure tray with battery compartment wrench. The last three turns of the wrench will activate the E-Z Flush unit. The E-Z Flush System is now operational.

Your E-Z Flush unit comes preset from the factory. If special circumstances require adjustment of the activation distance, see Appendix A – Adjusting Your E-Z Flush.

The E-Z Flush unit has a 10-minute start-up sequence in which the Object Lock Sensor will flash the User-In-View **yellow L.E.D.**

continuously as long as a user is in view. After the start-up sequence is completed and when the Object Lock Sensor has a user in view, the User-In-View **yellow L.E.D.** will flash only 3 times after a 5-second delay. This delay prevents needless flushes when someone walks by. Sensor units should not be located across from each other or in close proximity to highly reflective surfaces.

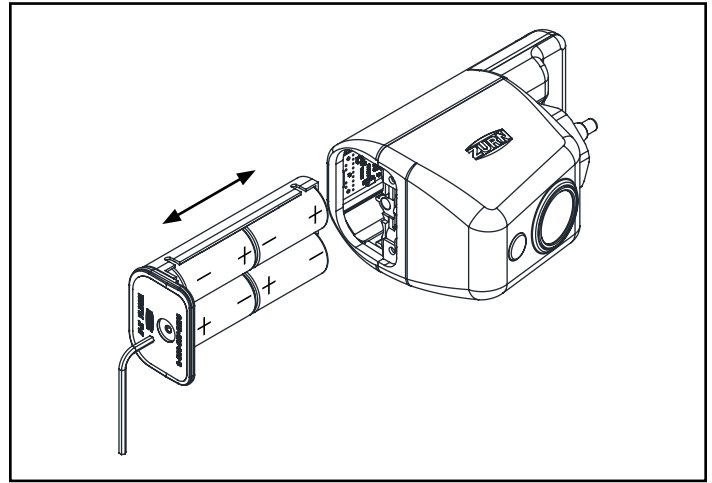

## Visual Indicator Guide

### 1. USER-IN-VIEW L.E.D.

Yellow light flashes 3 times – after 5-second delay – when a user is in view. The yellow light flashes constantly when a user is in view during the 10-minute start-up sequence.

### 2. OBJECT LOCK SENSOR

### 3. BATTERY L.E.D.

Red light flashes indicating it is time to replace batteries with 4 new “C” batteries.

### 4. COURTESY MANUAL FLUSH BUTTON

Allows manual activation of flush when needed.

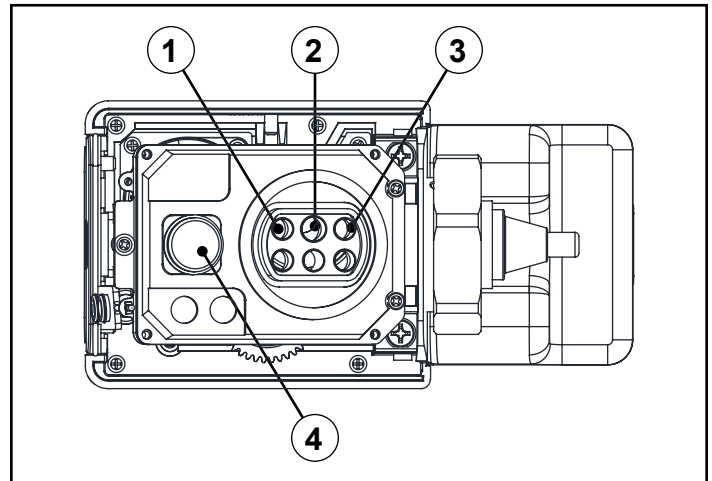

## Adjusting Your E-Z Flush

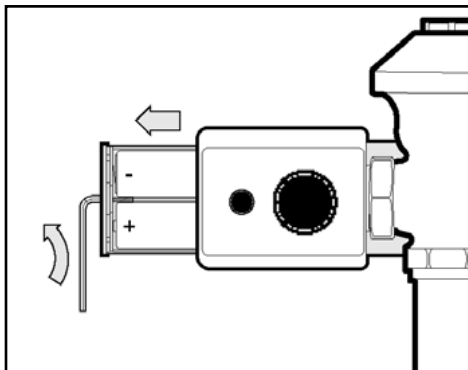

**STEP A** Use battery compartment wrench to remove battery compartment tray.

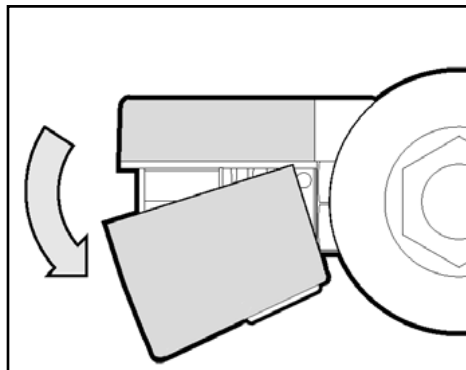

**STEP B** Pull cover off by rotating battery side forward and out.

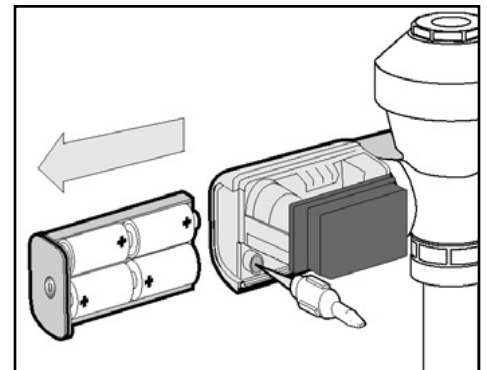

**STEP C** Sensor Adjustor Tool comes in a built-in storage pocket. Replace after use.

## Adjusting Your E-Z Flush - Cont.

Before the supply water is turned on, be sure all stop valves to the flush valves are closed off tight. The stop valves can be opened and closed by using the adjusting screw located at the center of the stop valve cap, behind the stop valve cover if already installed. Stop valve adjustments can only be made by using the adjusting screw.

**It is not necessary to remove the stop valve cap when making adjustments. If for any reason it becomes necessary to remove the stop valve cap, be certain the water is shut off at the main supply valve.**

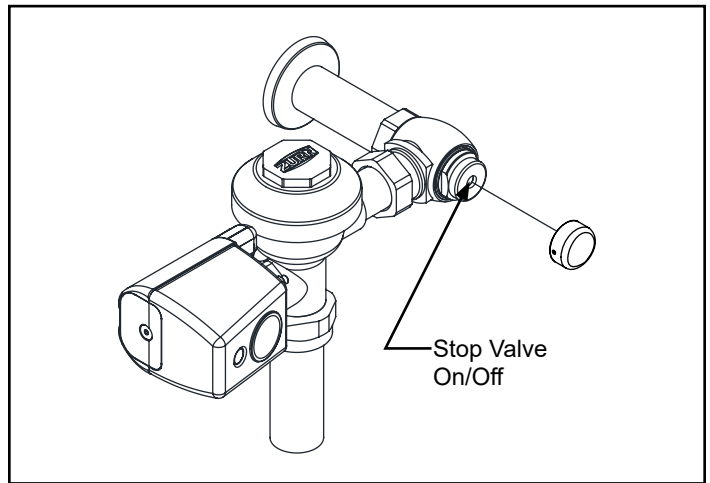

When all flush valves are connected to the fixtures and water pressure is available, it is recommended that the supply piping be flushed to remove dirt, pipe chips, etc., from system.

Use the following procedure to flush out the supply piping:

1. Remove the main valve body cover.
2. Remove the working parts from the flush valve shown on the right
3. Replace the plastic cover and main body cover without reinstalling the working parts.
4. Open the stop valve by using the stop adjusting screw and flush out all debris from pipe and connections.
5. Shut stop, open cover, reinstall the working parts, replace both covers and tighten.

This procedure should also be repeated when the system is drained for seasonal use, as occurs in athletic fields, recreation parks, etc.

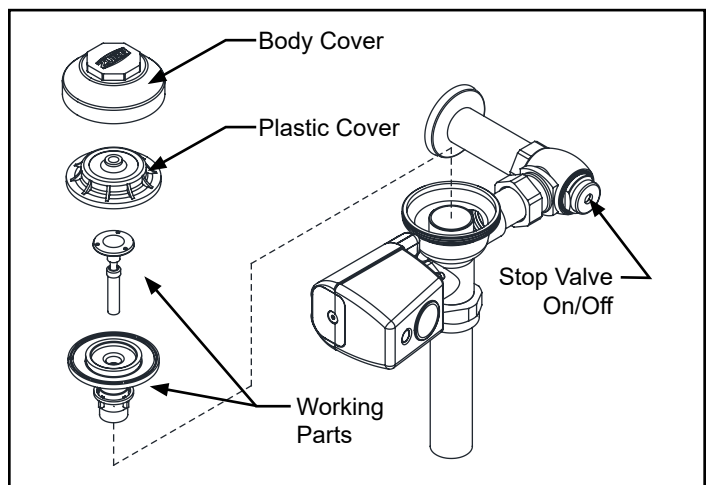

The ZER flush valves are preset for fixture volume as marked on the valve cartons. The valve does not require regulation for variation in water pressure within its operating range. To set the flush valve for proper operation, gradually adjust the stop valve open, using the adjusting screw, while actuating the valve until the rate of water flow into the fixture is not excessive, yet is sufficient to adequately evacuate the waste. The final setting for urinals should be such that the fixture will not overflow when the valve is actuated in succession. The stop cap screw cover should be replaced after final adjustments have been made.

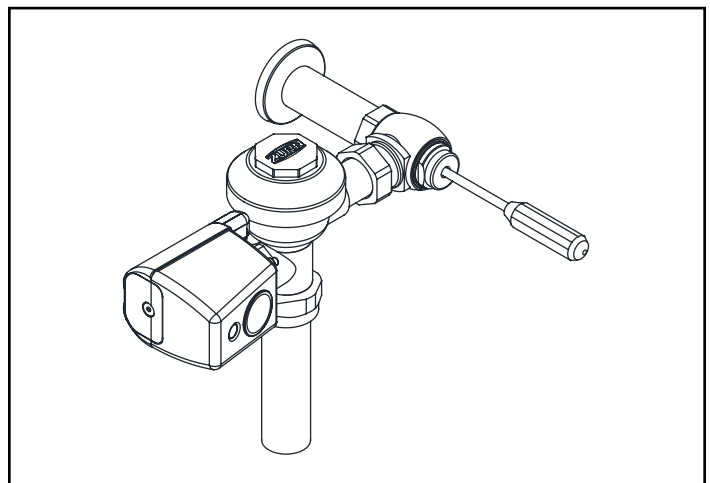

# Customized Sensor Range Setting

1. Remove battery compartment tray as shown in Step 6.
2. Remove cover and sensor adjustor tool as shown in Step 6.
3. Replace battery compartment in E-Z Flush to activate unit.
4. Press sensor range reset button (the yellow L.E.D. will flash continuously when it has an object in view for the 10-minute reset period).
5. Stand at desired activation distance.
6. Use sensor adjustor tool and turn **Distance Adjustment Screw** all the way down and then turn slowly up until **yellow L.E.D.** begins to flash.
7. Ensure Object Lock Sensor is not detecting stall door or wall by closing door, stepping out of sensor path and making sure **yellow L.E.D.** is not flashing. If sensor locks onto door or wall, unit will not flush properly. Shorten activation distance.
8. Remove battery compartment, replace sensor adjustor tool and cover. Replace battery compartment tray to reactivate E-Z Flush unit.
9. After 10-minute start-up sequence, the **yellow L.E.D.** will flash only 3 times when a user is in view (after a 5-second delay).

## Wiring Diagram

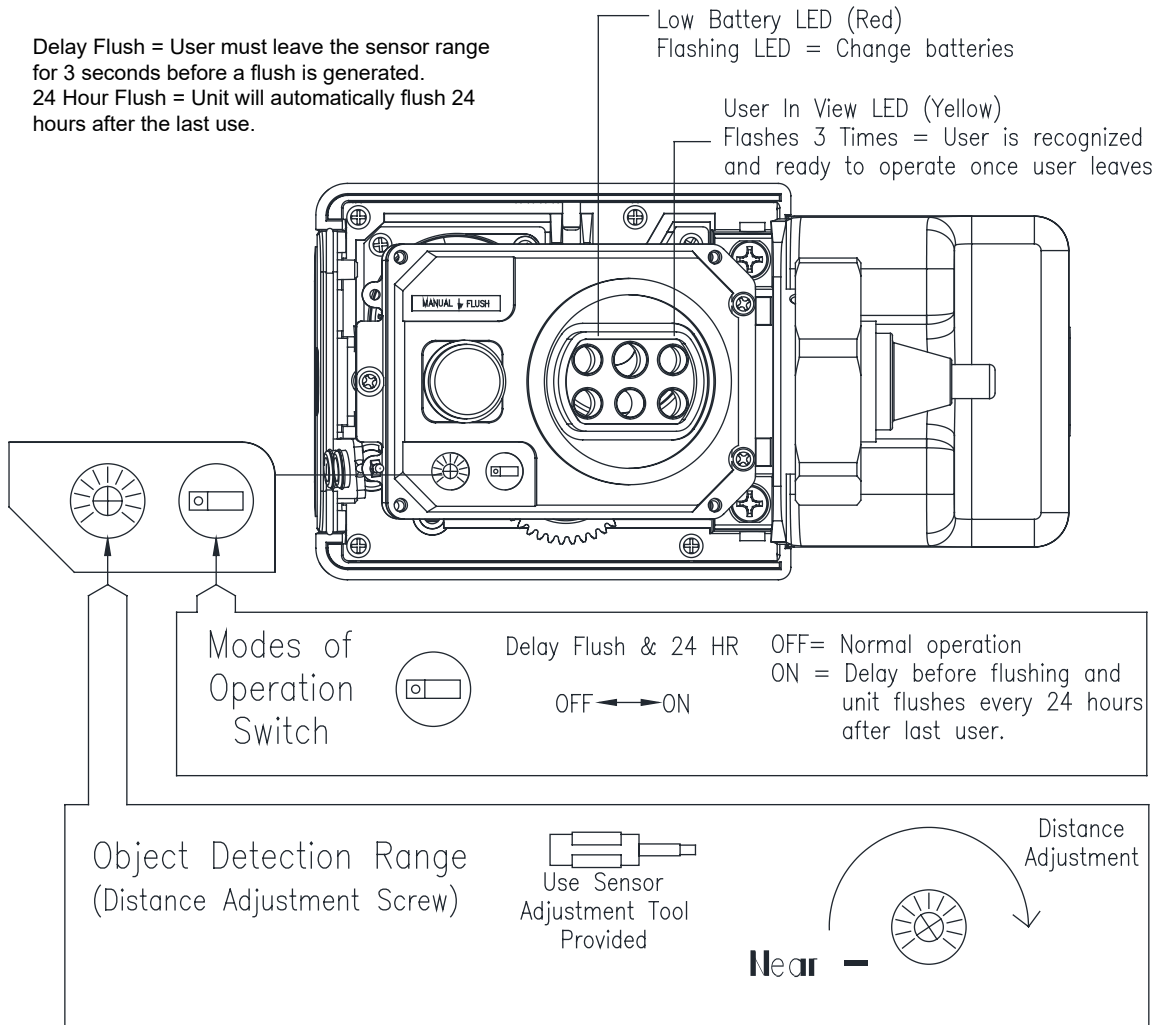



# Gateway Instruction

---

## Step 1. Request Gateway:

You can request your Ethernet or LTE gateway by visiting

[Zurn.com/plumbsmart-gateway-request](https://www.zurn.com/plumbsmart-gateway-request)

or call Zurn Customer Care at 1-844-987-6737

## Step 2. Cabling, Powering and Connecting Your Device:

1. Connect one end of the RJ45 Ethernet cable (supplied) to the gateway's Ethernet port and plug the cable's other end into the nearest wall port of the building's Ethernet network.
2. Connect the power supply to the power jack.
3. Wait for status LED to go from ON to double flash every second, the LoRa LED to turn ON solid, and the cell LED (if LTE enabled) to flash once every 3 seconds. Should take around 1-2 minutes depending on location. Your gateway is now ready to transmit data from your Zurn connected product.
4. Zurn Gateways have been set to DHCP by default. Please consult local IT support for possible additional access requirements for your network.

## Step 3. Determining general Location for the Zurn Gateway:

- Select a location central to all devices to be connected to this gateway. Place the gateway as high as possible, such as near the top of a wall.
- Avoid obstructions. Thick walls and reflective surfaces, such as metal, weaken the signal between the gateway and other devices.
- The LoRa antenna is an omni-directional antenna, but for best results, mount the device so the LoRa antenna is in a vertical position near the top of a wall. We recommend conducting a site survey to test the signal strength in different locations before you mount the device.

## Step 4. Mounting the Zurn Gateway:

The device ships with a mounting bracket. You will also need:

- Four #6 screws with anchors
  - Screwdriver
  - Drill
1. Determine where you want to mount the device.
  2. Mark where you want the screws to go.
  3. Drill holes for the screws and insert anchors.
  4. Place the mounting bracket and secure it with screws.
  5. Attach the device to the bracket and rotate to lock into place.

# Register in plumbSMART

---

NOTE: Instructions below are duplicated from registration card supplied with monitor

1. Install Zurn Connected Product(s)
2. Install Zurn Gateway per the Gateway Instructions Manual
3. Request plumbSMART Administrator Account at 844-987-6737
4. Zurn creates your Enterprise Account for you! (You will be required to identify your building location, number of floors, and number of rooms.)
5. Log in to [plumbsmart.zurn.com](https://plumbsmart.zurn.com)
6. Register each Connected Product in plumbSMART (Watch How-To Videos to Get Started. Located in the support section inside the portal.)
7. Now, Relax. You're Connected.



# Flush Valve Trouble Shooting Guide

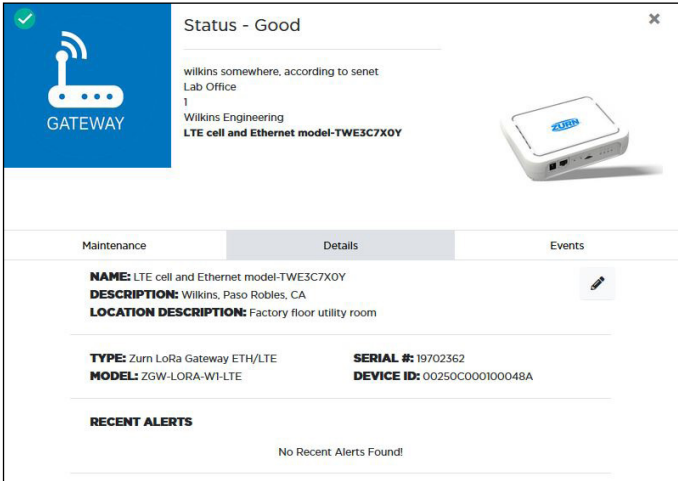

PROBLEM	CAUSE	SOLUTION
Yellow L.E.D. light flashes 3 times when there are no users.	Front of Object Lock Sensor is covered or Object Lock Sensor is set too far out, registering the opposite wall or door as a user.	Remove item covering sensor or adjust Object Lock Sensor activation distance. (See Appendix B – Adjusting the E-Z Flush.)
Yellow L.E.D. light flashes continuously when Object Lock Sensor is activated by a user.	E-Z Flush unit is in 10-minute start-up mode (when first activated), or Sensor Range Reset Button has been depressed.	Yellow L.E.D. light will flash only 3 times, acknowledging a user is in view after the 10-minute start-up mode.
Red L.E.D. light flashes.	Batteries need replacing.	Replace batteries.
Not enough water to fixture or too much water to fixture.	Diaphragm damaged or valve control stop improperly adjusted.	Replace diaphragm and/or adjust valve control stop.
Valve will not operate.	Object Lock Sensor range set too close to E-Z Flush, batteries are dead, or water supply is turned off.	Adjust Object Lock Sensor, replace batteries, or turn water on. If the E-Z Flush does not begin to function, call Customer Service at 1-800-997-3876.
Valve does not shut off.	Dirt or debris preventing diaphragm from functioning properly.	Remove dirt or debris, check by-pass hole in diaphragm.
Valve does not flush even after Object Lock Sensor has been adjusted.	Batteries are dead.	Replace batteries. If the E-Z Flush does not begin to function, call Customer Service at 1-800-997-3876.

## Trouble Shooting: Gateway

Problem	Corrective Action
<p>“Status – Good” posted in plumbSMART and faucet actuation event data not appearing in plumbSMART (&lt; 2 hours) or “Device Not Communicating” warning or severe alert posted in plumbSMART for all devices (&gt; 3 hours)</p> 	<p><b>Step 1</b> Verify gateway Status LED flashes twice every 2 seconds. If LED is OFF or ON solid, power cycle the gateway and wait for no more than 5 minutes for unit to initialize and connect.</p> <p><b>Step 2</b> After initialization is finished, LORA LED should turn ON solid within an additional minute.</p> <p><b>Step 3</b> If LORA LED does not turn ON solid and ethernet cable connected, contact facility IT administrator to modify port rules to allow Zurn gateway to access the internet via local router.</p> <p>If gateway model is ETH/LTE, visually verify SIM card is installed in designated slot on the side of gateway. If unit has a SIM card, then disconnect ethernet cable and power cycle the gateway and wait for unit to initialize and connect. LORA LED should turn ON solid after initialization.</p> <p><b>Step 4</b> If problem still present, move gateway closer to LoRa monitors and/or verify gateway mounting, orientation and connections comply with requirements listed in Zurn Gateway Installation Guide.</p> <p>Contact Zurn Customer Service at 1.855.ONE.ZURN (1.855.663.9876) for assistance with additional troubleshooting steps.</p>

For further assistance with troubleshooting, visit <https://plumbsmart.zurn.com/app/training>

# Trouble Shooting: LoRa Monitor

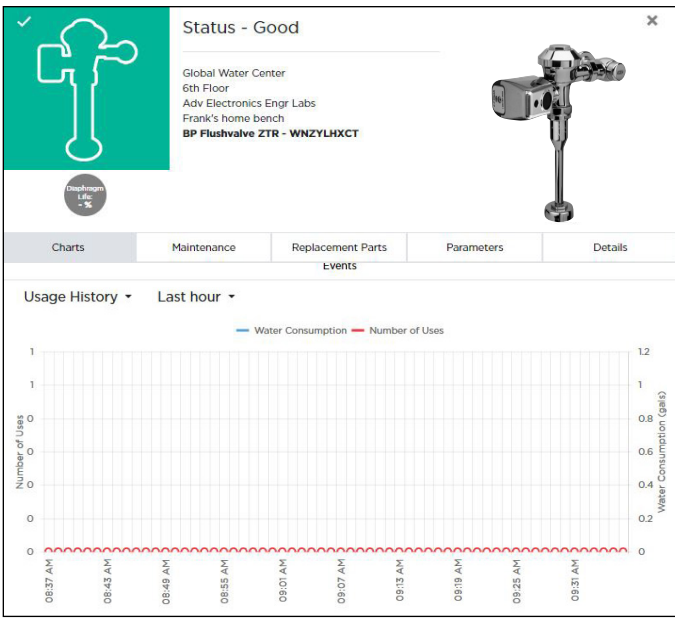
Problem	Corrective Action
<p><b>“Device Not Communicating”</b> posted in plumbSMART</p> 	<p><b>Step 1</b> Verify batteries installed in LoRa Monitor electronics and have sufficient charge. Install new batteries, as needed. Alert on product’s page in plumbSMART should clear within 1 hour or on next faucet activation. (Refresh web page by clicking on reload icon in the browser to clear the alert.)</p> <p><b>Step 2</b> If problem still present, verify gateway is within range of LoRa Monitor and functioning (see Gateway Troubleshooting section)</p> <p><b>Step 3</b> If problem still present, verify plumbSMART subscription status on product page’s Details tab listed as “Activated”</p> <p><b>NETWORK:</b> Senet <b>SUBSCRIPTION STATUS:</b> <i>Activated</i> <b>LAST HEARD FROM:</b> 07/14/2020, 04:29 PM CDT</p> <p>If listed as “Deactivated”, contact Zurn Custom Service at 1.855.ONE.ZURN (1.855.663.9876) for assistance.</p>
<p><b>“Status – Good”</b> posted in plumbSMART and faucet not actuating</p> 	<p><b>Step 1</b> Verify LoRa Monitor’s cables are connected to IR sensor and Faucet actuator electronics. Restore proper electrical connection, as needed.</p> <p><b>Step 2</b> Test activate the faucet.</p> <p>If problem persists, see Faucet Troubleshooting section in this guide for other steps.</p>
<p><b>“Status – Good”</b> posted in plumbSMART and faucet actuates but usage event data not appearing in plumbSMART Charts</p> 	<p><b>Step 1</b> Verify gateway is powered and LoRa Status LED is ON. If not, apply power per Zurn Gateway Installation Guide or see Gateway Troubleshooting section in this guide of other steps.</p> <p><b>Step 2</b> If problem still present, verify plumbSMART subscription status on product page’s Details tab listed as “Activated”</p> <p><b>NETWORK:</b> Senet <b>SUBSCRIPTION STATUS:</b> <i>Activated</i> <b>LAST HEARD FROM:</b> 07/14/2020, 04:29 PM CDT</p> <p>If listed as “Deactivated”, contact Zurn Customer Service at 1.855.ONE.ZURN (1.855.663.9876) for assistance.</p> <p><b>Step 3</b> If problem still present, the LoRa Monitor electronics may be faulty. Contact Zurn Customer Service at 1.855.ONE.ZURN (1.855.663.9876) for assistance with additional troubleshooting steps and, if needed, unit replacement.</p>

For further assistance with troubleshooting, visit <https://plumbsmart.zurn.com/app/training>

# Connected ZER6000 Series Parts Breakdown

## Part Identification

1. Seal
2. Collar Gasket
3. Sensor Module
4. Manual Override Push Button
5. Replacement Sensor Lens
6. Chrome Plastic Cover
7. Chrome Metal Cover
8. Battery Drawer
9. O-Ring
10. Allen Wrench
11. Handle Nut Wrench
12. Valve Body Cover
13. Plastic Cover
14. Trip Mechanism
15. Diaphragm Repair Kit
16. Valve Body
17. Vacuum Breaker Duckbill
18. Vacuum Breaker Tube
19. Vacuum Breaker Tube Nut
20. Spud Nut
21. Spud Friction Washer
22. Spud Sleeve
23. Spud Escutcheon
24. Tailpiece
25. Snap Ring
26. Tailpiece O-Ring
27. Locking Nut
28. Setscrew for Cast Wall Flange
29. Cast Wall Escutcheon
30. Supply Cover Tube
31. Sweat Solder Adapter
32. Stop Body
33. Piston Seal
34. Piston
35. Stop Spring
36. Guide O-Ring
37. Piston Guide
38. Guide Holder
39. Adjusting Screw
40. Stop Cap
41. Snap Cap Screw Cover
42. Vandal - Resistant Control Stop Cover
43. Setscrew for Control Stop Cover

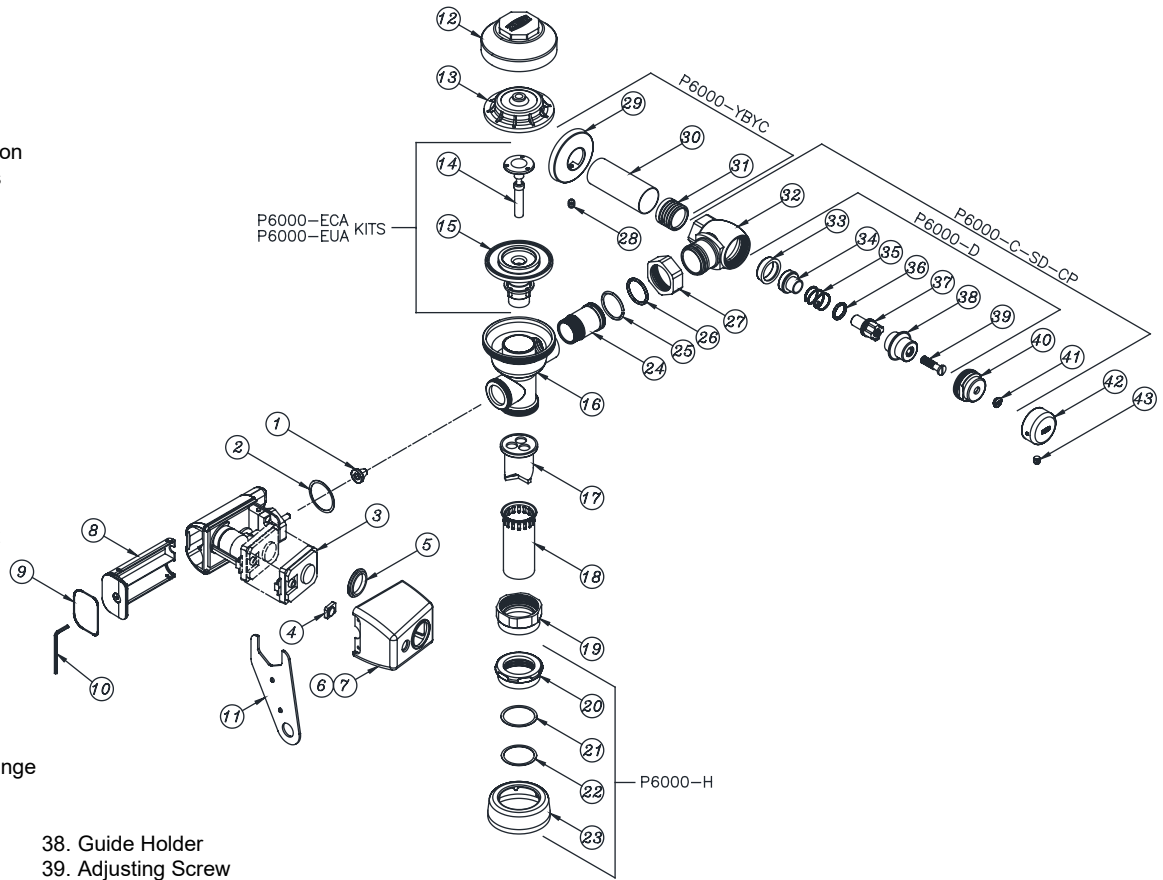

Covers and Repair Kits	Product No.
Outside Cover - CP - Item 10	P6000-LL-CP
Inside Cover - Item 11	P6000-L
Low Consumption Closet Kit - 1.28 gal. flush	P6000-ECA-HET
Low Consumption Closet Kit - 1.6 gal. flush	P6000-ECA-WS1
Water Saving Closet Kit - 3.5 gal. flush	P6000-ECA-WS
Full Flow Closet Kit - 4.5 gal. flush	P6000-ECA-FF
Ultra Low Flush Urinal Kit - 0.125 gal. flush	P6000-EUA-ULF
Extra Water Saver Urinal Kit - 0.5 gal. flush	P6000-EUA-EWS
Low Consumption Urinal Kit - 1.0 gal. flush	P6000-EUA-WS1
Water Saving Urinal Kit - 1.5 gal flush	P6000-EUA-WS
Full Flush Urinal Kit - 3.0 gal. flush	P6000-EUA-FF

Repair Parts - Inside Parts	Product No.
Urinal Relief Valve - Item 12	P6000-EU13
Closet Relief Valve - Item 12	P6000-EC13

Flush Connections and Spud Coupling Kits	Product No.
Flush Tube Assembly for Flush Valves Includes Items 15-19, Specify Diameter and Length	P6000-A
Vacuum Breaker Repair Kit, Item 17	P6000-B
Spud Coupling Assembly Includes Items 20-23 Specify Size.	P6000-H

Control Stop Repair Kit and Parts	Product No.
Control Stop Repair Kit for 1" and 3/4", Includes Items 33-39	P6000-D-SD
Seal Seat for 1" and 3/4", Includes Item 33	P6000-D42
VP Control Stop Repair Kit for 1" and 3/4", Includes Items 33-39	P6000-D-VP
Sweat Solder Connection with Cast Wall Flange, Includes Items 29-31	P6000-YBYC

Adjustable Tailpieces	Product No.
Adjustable Tailpiece for Standard Flush Valve Includes Items 24-26	P6000-J1
Tailpiece Coupling Assembly Includes Items 25-27	P6000-K
Tailpiece Locking Ring Includes Item 25	P6000-C30
Tailpiece O-Ring Includes Items 26	P6000-C31
Coupling Nut Includes Item 27	P6000-C32

Handle Assembly and Repair Kits	Product No.
Chrome Plastic Cover, Item 6	PERK6000-L-CPCR
Chrome Metal Cover, Item 7	PERK6000-L-CPMCR
Replacement Sensor Lens Item 5	PERK6000-SCR
Battery Drawer, Item 8	PERK6000-BD
Repair Kit Includes Items 1, 2, 4, and 9	PERK6000-RK
Repair Kit Includes Items 1, 2, Retainer and Cup Seal	PERK6000-MRK
Sensor Module	PERK6000-SR

Rev. B | Date: 11/11/22 | C.N. No. 144844 | Prod./Dwg. No. FV746

---

Patent [zurn.com/patents](http://zurn.com/patents)

US 1.855.0NE.ZURN CANADA 1.877.892.5216

**ZURN.COM**

by **zurn ELKAY** Water Solutions