

Smart Backflow Wireless Monitor

Note: This product to be installed in an indoor, dry or damp location only.



Installation Instructions

CAUTION: Do not power unit until backflow preventer valve has been installed, pressurized and stable.

1. Install backflow preventer valve per Zurn Wilkins backflow preventer valve installation guide.

STANDARD MOUNTING

Electronics enclosure and electronics/sensors are pre-installed on the standard backflow preventer valve.

On model FCIS, once the ZW206 and backflow preventer have been installed, plug the pressure sensor cable from the enclosure into the pressure transducer on the backflow preventer cover. Route the black position sensor housing to the relief valve cover under the backflow preventer and attach with the two screws and 5/32" allen wrench.

Typical Installation

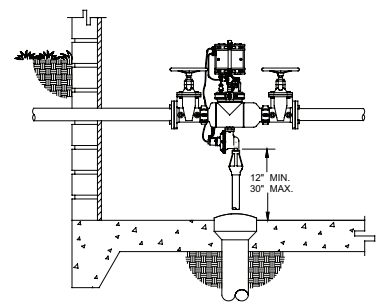
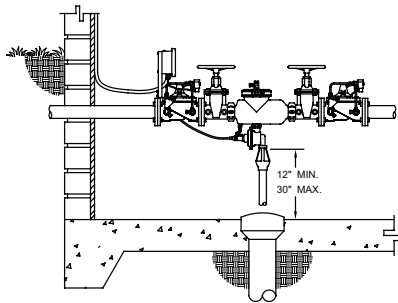
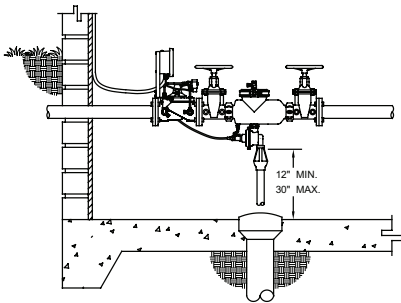

Single Water Shutdown

A single ZW206 Solenoid Control Valve to shutdown the water supply to the backflow preventer and system is our standard installation. This will prevent the discharge of water through a fouled first check.

Double Water Shutdown

Two ZW206 Solenoid Control Valves to isolate the Reduced Pressure Backflow Assembly on both the inlet and outlet. A second ZW206C installed downstream will prevent water discharge due to a fouled second check.

PLACING THE DEVICE IN SERVICE

1. Plug unit into a 120 VAC grounded outlet and wait 60 seconds for the electronics to initialize before moving to step 2. GREEN LED on enclosure will turn on.
2. Toggle the switch position to the ZERO position and hold for three seconds, this will set the closed position of the backflow relief valve position monitor.

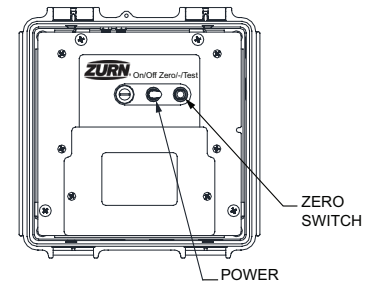

ALTERNATE MOUNTING INSTRUCTIONS

1. Remove electronics enclosure from Unistrut or brackets on left ACV.
2. Locate mount hardware shipped with the electronics enclosure (taped to the side of the enclosure)
3. Install the wall mount brackets onto the electronics enclosure using the self-tapping pan-head screws provided (see picture on the right)
4. Position the enclosure on a wall 3' from the floor to the bottom of the enclosure in a secure area. The position of the enclosure must be within 4' of the backflow preventer valve and sensors
5. Mount the enclosure to the wall with appropriate fasteners to meet the mounting application.
6. Refer to the "Placing the device in service" above

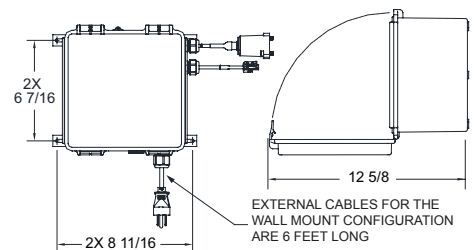

Model 375ASTW1 with NRS option

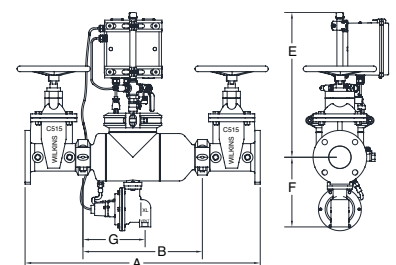

Backflow Preventer with Wireless Monitoring – Model List *Sizes (2 1/2" - 10")
375ASTW1, 375AW1, 375W1

▲WARNING: Cancer and Reproductive Harm - www.P65Warnings.ca.gov
▲ADVERTENCIA: Cáncer y daño reproductivo - www.P65Warnings.ca.gov
▲AVERTISSEMENT: Cancer et néfastes sur la reproduction - www.P65Warnings.ca.gov



Features

Input: 120vac, 1.24amps max
120 vac output: 50ma max
24vac output: 50 watts, 50 VA, or 2A max
Alarm contact rating: 3A
Replacement Fuse: 1.25 amp slow blow

Operation

The backflow relief valve monitor senses the position of the relief valve plunger and the zone pressure. When the relief valve opens, it calculates the amount of water discharged and sends a signal to the automatic control valve (ACV) to shut down the water supply when discharge exceeds the maximum daily discharge allowed. This is factory set at 50 gpm but can be adjusted when subscribing to the Zurn connected products portal. External trigger switches (i.e. float switch, water sensor, etc) that provide contact closure can also be connected to turn off the water supply. To test the function of the water shutoff, push the toggle switch to the TEST position. The red light on the top of the box will come on and the solenoid valve will close. Turn the power switch Off and back On to reset the ACV. Alarm contacts are also provided to send a shutdown signal to an alarm panel or building monitoring system.

Connections

The pressure sensor cable and relief valve position cables are already attached to the relief valve monitor box. The pressure sensor cable must be plugged into the zone pressure transducer on the cover of the backflow preventer. The relief valve position sensor is attached to the end of the cable in a composite protective cover. This cover attaches to the backflow preventer relief valve.

Warning: All electrical connections should be made by qualified personnel.

To connect alternate triggers, outputs or alarm cables, first turn off power and unplug the power cable to the box. Then remove the two screws holding the lower cover panel inside the box. The two wires from an alternate trigger that provides contact closure can be connected to the two terminals labeled Trigger A, T1&T2. A second alternate trigger device can be connected to Trigger B, T3&T4.

Wires for the ACV solenoid on the model FCIS should already be connected to the ACV#1 or ACV#2 terminals. If adding another ACV, these terminals provide 24vac output and can only be used on a solenoid rated for 24vac. The solenoid ground wire should be connected to GND, T8. One of the two coil wires will connect to 24V COM terminal T7 or T11 and the second coil wire will connect to the NO 24VAC, T5 or T9, or NC 24VAC terminal, T6 or T10. If the solenoid is Normally Open (requires power to close) then connect to the NO terminal. The NC terminal is used for a Normally Closed (power to open) solenoid valve.

The AUX terminals are used to connect to an external alarm or building monitoring system. These terminals provide contact closure only. Use Normally Closed NC T12 or Normally Open NO T14 as required with the common COM T13 terminal.

The AUX PWR terminals, T15, T16, T17, can be used to provide 120vac output power for a relay, 50ma max. When the alarm outputs are not used, T12, T13, T14, the 120v can be routed through the AUX relay and turn 120 vac on or off when the box goes into alarm.

Warning: A solenoid shutoff valve should not be installed on a system that must be supplied with water at all times (i.e. a hospital, processing plant, etc.) unless a back-up supply is also installed. If water must remain on during a power failure, a normally open automatic control valve should be ordered.

If the downstream piping is above the backflow preventer, then a failed 2nd check could cause relief valve discharge to continue draining a system after the supply is off. For systems with large amounts of water, like a high-rise building, a single check valve or solenoid shutoff valve that works as a check valve should be installed after the backflow preventer.