

Model ZW209FP

Fire Protection Pressure Reducing Valve Assembly
Globe and Angle Pattern Bodies
1-1/4", 1-1/2", 2", 2-1/2", 3", 4", & 6"



□ Installation □ Start-up □ Maintenance Instructions

DESCRIPTION

The Zurn Wilkins Model ZW209FP pilot operated pressure reducing valve is designed specifically for fire suppression systems to reduce high inlet pressures to a safe and stable outlet pressure. The pilot assembly reacts to changes in downstream pressure allowing the main valve to modulate between the closed and open position ensuring a constant downstream set pressure. Once the downstream pressure reaches the pilot setting, the main valve will seal shut preventing damage downstream. Pressure regulation is not dependent upon flow rate, resulting in minimal pressure loss through the valve. In addition the ZW209FP comes standard with red epoxy coating internally and externally for corrosion protection, as well as pressure gauges for quick and easy maintenance or repair. The ZW209FP is available in both globe and angle pattern bodies.

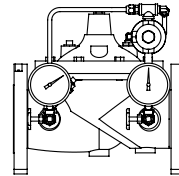

ZW209FP
Class 300 Flanged
Max 300 psi Inlet

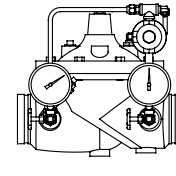

ZW209FPG
Grooved
Max 300 psi Inlet

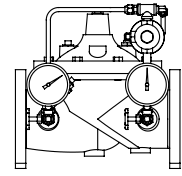

ZW209FPX
Class 150 Flanged
Max 250 psi Inlet

ZW209FPTH
Threaded
Max 300 psi Inlet



Installation / Start-up

INSTALLATION

NOTE: Prior to installation of the ZW209FP, ensure that all debris is flushed out the piping system before installed.

1. During the installation of a ZW209FP in a sprinkler system, Underwriter Laboratories (UL) requires NFPA 13 "Standard for Installation of Sprinkler Systems" be followed.
2. Upon installation UL also requires that the ZW209FP be tested in accordance with NFPA 13 or NFPA 14. Thereafter the valve shall be inspected, tested, and maintained in accordance to NFPA 25 "Standard for the Inspection, Testing, and Maintenance of Water-Based Fire Protection Systems". **NOTE: Initial testing must be done with the design inlet pressure so the proper outlet pressure can be verified.**
3. For making adjustments and servicing allow for adequate space around the valve.
4. When installing a ZW209FP valve gate valves installed on both inlet and outlet are recommended for maintenance allowing for isolation of valve.
5. Position the ZW209FP in line matching the direction of flow as indicated on the valve model tag with the proper direction of flow in the system. Once attached to line double check all fasteners/bolts in the pilot system and on main valve are tight and there is no damage prior to pressurizing system.
NOTE: Pressure in some applications can be very high so be thorough in checking and inspecting for proper installation and makeup.
6. Valves installed in sprinkler or standpipe systems shall have the following:
 - a. Union or rubber gasket fittings installed immediately up stream or downstream to permit replacement.
 - b. A relief valve (at least 1/2" size and 175 psi max.) installed on the downstream side and plumbed to a safe drainage.
 - c. Pressure gauges installed on the inlet and outlet.
 - d. Shall not be set for less than 50 psi.
7. It is suggested that a line size tee connection be installed downstream of sprinkler system valves to allow flow testing as required every five years per NFPA 25.

8. Bleed all trapped air from supply riser and sprinkler system. Trapped air may cause outlet pressure fluctuations at low flows.

9. Zurn Wilkins valves are designed to operate in both the vertical and horizontal positions. However, it is recommended that ZW209FP's 6" and larger, be installation in the horizontal position. The horizontal positioning of the larger valves avoids premature wear due to mass of plunger assemblies as well as allows for greater accessibility during annual inspections, and maintenance.

START-UP

CAUTION: To prevent personnel injury and damage to equipment check that downstream venting is adequate prior to start-up and test procedures. All adjustments under pressure should be made slowly while under flowing conditions. If the main valve closes too fast it may cause surging in upstream piping.

1. Slowly open the upstream shutoff valve only enough to fill main valve assembly and pilot system. Prior to pressurizing the valve assembly it is also recommended that a ZPI valve position indicator be installed to aid in verifying proper valve movement.
2. As the valve is filling with water, it is necessary to bleed the main valve and pilot system of air. To vent air, partially open or loosen the highest plugs or fittings in the system. The ZPI valve position indicator is a great location, as it has a test cock at the top to vent air pressure. It may be necessary to bleed system more than once. After removal of air in the system tighten all loose fittings. **NOTE: If valve is installed vertically, it will be necessary to loosen some upper cover bolts until you have vented all the air from the cover chamber.**
3. At this point with the upstream shutoff valve partially open slowly open the downstream shut off valve. Flow will begin to occur and pressure should build up in valve and eventually stabilize.

⚠ **WARNING:** Cancer and Reproductive Harm - www.P65Warnings.ca.gov
⚠ **ADVERTENCIA:** Cáncer y daño reproductivo - www.P65Warnings.ca.gov
⚠ **AVERTISSEMENT:** Cancer et néfastes sur la reproduction - www.P65Warnings.ca.gov



Installation / Start-up

4. To adjust pressure setting on the PV-PRD, water must be flowing through the pilot in order to accurately set pressure (refer to table 1 for recommended flow). Then loosen jam nut on adjustment screw and either turn adjustment screw in (to increase pressure) or out (to decrease pressure) of the PV-PRD.

5. To verify proper operation of ZW209FP slowly close and open downstream shut off valve several time to ensure downstream pressure is stable at set pressure.

6. The suggested flow calculations (Table 1) are based on the flow through schedule 40 pipe. Maximum continuous flow is approximately 20 ft/s (6.1 m/s) & maximum intermittent is approximately 25 ft/s (7.6 m/s) and minimum continuous flow is approximately 1 ft/s (0.3 m/s). Many factors should be considered in sizing pressure reducing valves including inlet pressure, outlet pressure, and flow rates.

NOTE: For additional system protection a pressure relief valve (1/2" min) shall be installed downstream of pressure reducing valve.

Table 1

VALVE SIZE	inches	1-1/4	1-1/2	2	2-1/2	3	4	6
	mm	32	40	50	65	80	100	150
MINIMUM FLOW RATES TO SET VALVE (GPM)		15	15	100	35	60	100	220
MAX. FLOW RATE (GPM)		125	160	250	375	600	1000	2250

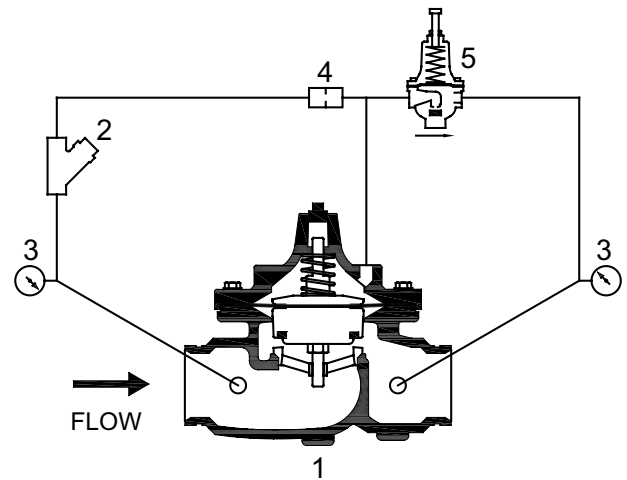

ZW209FPG SCHEMATIC STANDARD COMPONENTS

1. Main Valve
2. SXL "Wye"
3. Pressure Gauge
4. Restriction Tube Fitting
5. PV-PRD Pressure Reducing Control

Operation

The Zurn Wilkins ZW209FP utilizes a pressure reducing pilot valve that installs on the discharge side of the control circuitry. The pilot Model PV-PRD is a direct acting, normally open, spring loaded, diaphragm actuated valve. The operation of the ZW209FP begins with accurately sizing the valve, then fine tuning the control circuitry by adjusting the PV-PRD to the desired downstream pressure.

Inlet pressure is piped to the inlet of the PV-PRD. A sensing line runs internally from the discharge side of the pilot to its lower control chamber under the diaphragm. Thus, downstream pressure exceeding the preset of the pilot acts to close the pilot valve while the adjustable spring in the pilot seeks to keep it open. The result is a modulating action in the pilot that is transmitted to the cover of the main valve. This creates a mirror modulation of the diaphragm assembly in the main valve. Downstream pressure is maintained with narrow limits regardless of changing flow rates or varying inlet pressure.

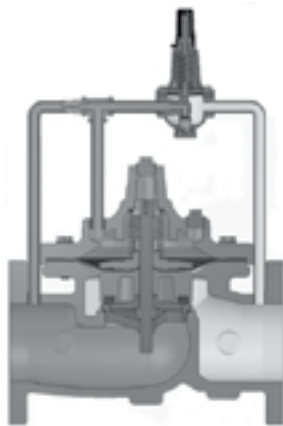

Drip Tight Closing Operation

With the use of a three way pilot control, inlet pressure is directed to the cover where the pressure forces the valve closed.



Full Open Operation

Using a three way pilot control, pressure relief (typically to atmosphere) can be controlled to the cover that enables the inlet pressure to open the main valve.

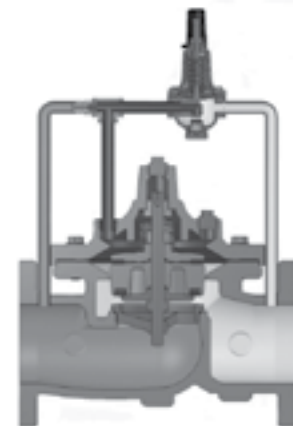

Modulating Action

Utilizing a Wilkins modulating control system, pressure changes to the cover can be controlled, allowing the valve to throttle and compensate for changes.

Flow Characteristics

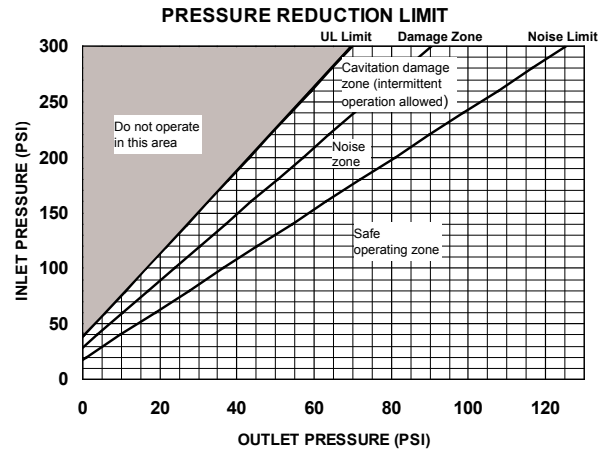
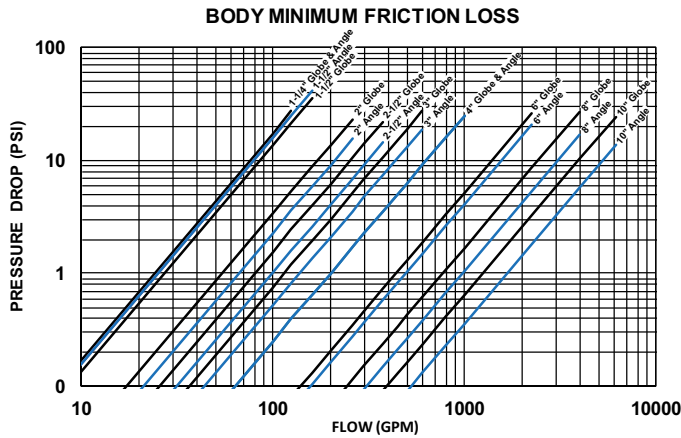

*** Notes for Body Minimum Friction Loss Chart:**

Minimum inlet pressure is 10 psi higher than set point or the additional body friction loss at intended flow, whichever is higher. (friction loss may be important at flows above 20 ft/s)
 Example: A 6" valve intended to flow 2000 GPM at 150 psi has a friction loss of 20 psi at 2000 GPM. The minimum inlet pressure would be 150 + 20 = 170 psi. When inlet pressure is below set point, the outlet pressure will be the pressure at the inlet minus the friction loss.

Maintenance Instructions

MAINTENANCE (Main Valve)

In addition to complying with UL standard NFPA 25 every five years, scheduled preventative maintenance and inspection is highly recommended. It is also recommended that a repair kit with a new diaphragm, disc, and o-rings be on hand before work begins

DISASSEMBLY

Warning: With the ability to perform inspections and maintenance without removal from the system. It is very important that all shut off valves be closed and all pressure relieved in the valve before beginning disassembly. Failure to do so can result in personnel injury or equipment damage.

1. With all isolation valves closed to the ZW209FP, begin slowly removing flare fitting in the pilot system until residual pressure is removed. After excess pressure has been relieved begin removal of pilot tubing to cover.
2. Begin loosening cover bolts and remove cover lifting up to slide cover bushing off plunger shaft. For valves larger than 6" it is recommended that lifting lugs and a hoist be used due excessive weight of the larger covers.
3. Once the cover is removed the plunger spring and spring washer can be removed. Then remove the diaphragm assembly by grabbing the stem or lifting from two sides of the diaphragm. Be sure to lift straight up to avoid binding the stem in the seat bushing, as damage can occur. **NOTE:** Again with the larger size valves 6" and up it is recommended that a lifting lug and hoist be used to remove larger plunger assemblies.
4. Place diaphragm assembly in a vise with the bottom hex secured. Remove the stem nut and inspect threads for damage, corrosion, or pitting.
5. After inspecting the stem and removing the nut the diaphragm

assembly can be dismantled. When disassembling be sure to clean, inspect, and save all components. Replace any damaged components as necessary.

6. Next clean and inspect the seat inside the main valve body. If excessive water deposits are present fine grit sand paper can be used to clean. The seat is designed to be removed, but typically does not require removal. If damage is noticeable or seat is excessively worn, replace the seat before reassembly.

7. Refer to www.zurn.com to find ZW209 instruction sheet for more detailed instructions for disassembly and reassembly of main valve.

REASSEMBLY

Prior to reassembly clean, inspect, and replace any parts as needed.

1. Using a vise, diaphragm assembly can be held and assembled in the reverse order as disassembly section.
2. Clamp valve stem hex in a vise and reassemble diaphragm assembly. Make sure to **center diaphragm** on plunger before placing diaphragm disc. Refer to ZW209 instruction sheet at www.zurn.com or call product support 877-222-5356 for further assistance.
3. Once diaphragm assembly is assembled, gently lower stem into seat guide. Rotate diaphragm as needed until bolt holes line up with body bolt holes.
4. Install spring then the cover. Tighten bolts in a cross pattern. Be careful not to pinch the diaphragm when inserting and tightening cover bolts.
5. Reattach pilot assembly and tighten all bolts and fitting as needed. Test system per UL standard NFPA 25.



Maintenance Instructions

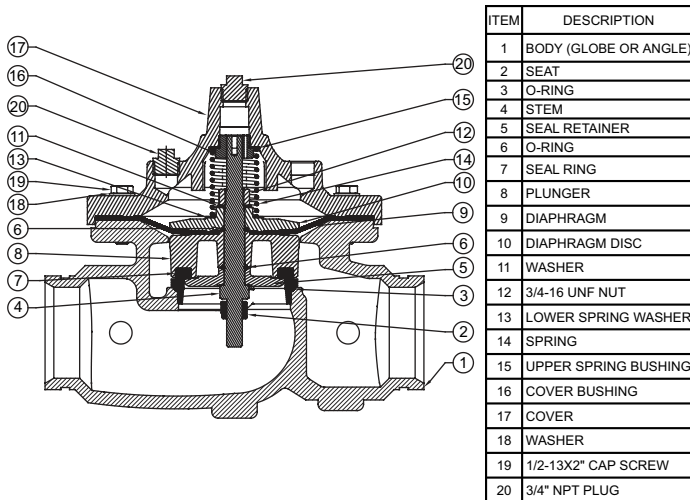

ITEM	DESCRIPTION
1	BODY (GLOBE OR ANGLE)
2	SEAT
3	O-RING
4	STEM
5	SEAL RETAINER
6	O-RING
7	SEAL RING
8	PLUNGER
9	DIAPHRAGM
10	DIAPHRAGM DISC
11	WASHER
12	3/4-16 UNF NUT
13	LOWER SPRING WASHER
14	SPRING
15	UPPER SPRING BUSHING
16	COVER BUSHING
17	COVER
18	WASHER
19	1/2-13X2" CAP SCREW
20	3/4" NPT PLUG

MAINTENANCE (3/8" PV-PRD VALVE)

The PV-PRD pressure reducing control may be installed in any position. There is one inlet port and two outlets, for either straight or angle installation. A flow arrow is marked on the body and should be oriented as needed.

DISASSEMBLY

Prior to disassembly, relieve all pressure in pilot system and then remove the PV-PRD.

1. Secure valve body and remove main cap on bottom of valve using an adjustable wrench.
2. Use a 13 mm socket to remove the plunger.
3. Next remove adjustment cover (plastic cover), 3/8" adjustment bolt with nut, 8 socket head screws around the pilot bell using a 5/32 hex key, spring, and spring disc.
4. At this point the PRV stem yoke is free to move and can be slid out of the valve body.
5. Continue to remove the 5/16" diaphragm nut, lock washer, and diaphragm retainer.
6. After completely disassembling, thoroughly clean and inspect all components before reassembly. Replace any parts as necessary after inspection.
7. The pilot seat generally does not need to be removed, but if after inspection it requires replacement it can be removed with a 1/2" socket.

3/8" PV-PRD VALVE

REASSEMBLY

Reassembly of the PV-PRD is the reverse of disassembly.

1. Install the new o-ring on top of pilot yoke threads followed by new diaphragm and diaphragm retainer. Then place lock washer over pilot yoke stem along with the 5/16" diaphragm nut and tighten. Diaphragm bolt holes must be centered on yoke legs. See following diagram
2. Next carefully slide yoke assembly into body and around pilot seat.

CENTER YOKE LEGS
BETWEEN
DIAPHRAGM HOLES

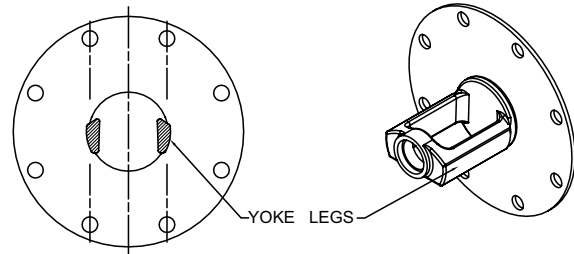

NOTE: Line up diaphragm screw holes with holes in body. Move yoke up and down checking for yoke contacting or dragging on valve body.

3. Then attach plunger to the bottom of the pilot yoke via the main cap hole and tighten with a 13 mm socket.
4. Install main cap in bottom of valve body with new o-ring.
5. Install spring, spring disc, and pilot bell on the valve body.
6. Insert socket head cap screws into pilot bell holes and thread into valve body. Tighten all screws in a cross pattern.
7. Install adjusting screw by hand with jam nut. Set valve once reinstalled into main valve pilot system. For setting pilot refer to "Start Up" section on page one. For further assistance or ordering replacement parts go to www.zurn.com or call product support 877-222-5356.

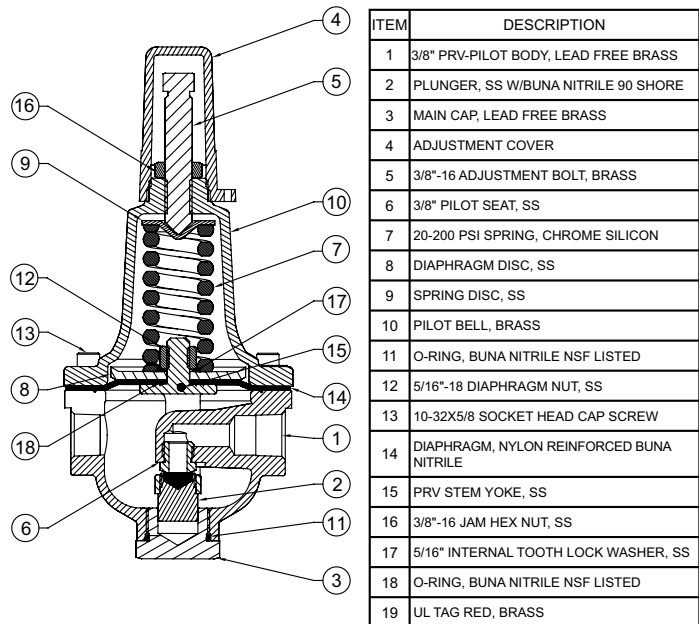

ITEM	DESCRIPTION
1	3/8" PRV-PILOT BODY, LEAD FREE BRASS
2	PLUNGER, SS W/BUNA NITRILE 90 SHORE
3	MAIN CAP, LEAD FREE BRASS
4	ADJUSTMENT COVER
5	3/8"-16 ADJUSTMENT BOLT, BRASS
6	3/8" PILOT SEAT, SS
7	20-200 PSI SPRING, CHROME SILICON
8	DIAPHRAGM DISC, SS
9	SPRING DISC, SS
10	PILOT BELL, BRASS
11	O-RING, BUNA NITRILE NSF LISTED
12	5/16"-18 DIAPHRAGM NUT, SS
13	10-32X5/8 SOCKET HEAD CAP SCREW
14	DIAPHRAGM, NYLON REINFORCED BUNA NITRILE
15	PRV STEM YOKE, SS
16	3/8"-16 JAM HEX NUT, SS
17	5/16" INTERNAL TOOTH LOCK WASHER, SS
18	O-RING, BUNA NITRILE NSF LISTED
19	UL TAG RED, BRASS

PV-PRD SPECS:

Adjustment Range Pressure:	50-165 psi
(Flowing residual outlet pressure)	
Max Static Outlet Pressure:	175 psi
Max Inlet Pressure:	300 psi

NOTE : All adjustments should be made with a pressure gauge and while flowing water through the main valve.

ZURN WILKINS

1747 Commerce Way, Paso Robles, CA 93446 Phone:855-663-9876 Fax:805-238-5766