

Model ZW215FP

Fire Pump Suction Control Valve
Globe and Angle Pattern Bodies
2", 2-1/2", 3", 4", 6", 8", & 10"



□ Installation □ Start-up □ Maintenance Instructions

DESCRIPTION

The Zurn Wilkins Model ZW215FP Fire Pump Suction Control Valve is designed specifically for Fire Suppression Systems to prevent fire pumps from over-drawing from the water supply resulting in damage to the pump or the supply network because of very low or negative pressures on the suction side of the fire pump. The pilot assembly reacts quickly to increases and decreases of suction pressure. The control valve will close if suction pressure drops below the set pressure. The control valve will open again once suction pressure rises to the control valve set pressure and will modulate to keep the suction pressure at the set pressure until supply increases. In addition the Model ZW215FP comes standard with red epoxy coating internally and externally for corrosion protection, as well as a test cock on the sensing port for quick bleeding of sensing line. The ZW215FP is available in both globe and angle pattern bodies.

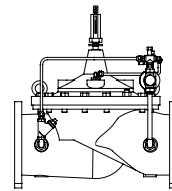

ZW215FP
Class 150 Flanged
Max 250 psi Inlet

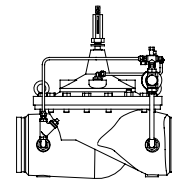

ZW215FPG
Grooved
Max 300 psi Inlet

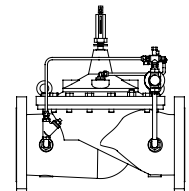

ZW215FPY
Class 300 Flanged
Max 300 psi Inlet



ZW215FPTH
Threaded
Max 300 psi Inlet

Installation / Start-up

INSTALLATION

NOTE: Prior to installation of the ZW215FP, ensure that all debris is flushed out the piping system before installed.

1. During the installation of a ZW215FP in a sprinkler system, verify installation meets requirements of local law or the Authority Having Jurisdiction.
2. Allow for adequate space around the valve for making adjustments and servicing.
3. Position the ZW215FP in line matching the direction of flow as indicated on the valve model tag with the proper direction of flow in the system. The valve must be installed on the discharge side of the fire pump.
4. Connect pilot control sensing connection to the suction side of the pump by minimum 3/8 in diameter tubing.
5. Once control valve and sensing line are installed, double check all fasteners/bolts in the pilot system and on main valve are tight and there is no damage prior to pressurizing system.

NOTE: Pressure in some applications can be very high so be thorough in checking and inspecting for proper installation and makeup.

6. Zurn Wilkins valves are designed to operate in both the vertical and horizontal positions. However, it is recommended that ZW215FP's 6" and larger, be installation in the horizontal position. The horizontal positioning of the larger valves avoids premature wear due to mass of plunger assemblies as well as allows for greater accessibility during annual inspections, and maintenance.

START-UP

CAUTION: To prevent personnel injury and damage to equipment check that downstream venting is adequate prior to start-up and test procedures. All adjustments under pressure should be made slowly. If the main valve opens or closes too fast it may cause surging in upstream piping.

1. Pressurize the upstream side of the ZW215FP.
2. As the valve is filling with water, it is necessary to bleed the main valve and pilot system of air. To vent air, partially open or loosen the highest plugs or fittings in the system. The ZPI valve position indicator is a great location, as it has a test cock at the top to vent air pressure. It may be necessary to bleed system more than once. After removal of air in the system tighten all loose fittings. **NOTE: If valve is installed vertically, it will be necessary to loosen some upper cover bolts until you have vented all the air from the cover chamber.**
3. Install a pressure gauge on the suction side of the pump or install a gauge in the test cock on the sensing line to read the suction pressure.
4. Loosen the pilot adjustment screw until the adjustment screw can be turned by hand. **Note: A small amount of spring force must be maintained so the spring and spring discs do not fall out of alignment. Do not loosen the pilot adjustment screw completely. Note: The control valve should open and allow a lot of water to flow. If there is no flow, continue turning the pilot adjustment screw counterclockwise.** Once water is flowing through the control valve it is necessary to lower the suction pressure below the desired set pressure. One can cause the suction pressure to decrease by increasing flow through the pump or using a valve upstream of the pump suction to throttle water to the pump.
5. Once suction pressure is below desired minimum suction pressure, **slowly** turn the pilot valve adjustment screw clockwise. As the screw is tightened the control valve will slowly start to close causing upstream pressure to increase. Continue turning adjustment screw clockwise until suction pressure is stable at the desired set pressure.
6. Tighten adjustment screw jam nut once step 4 is completed. To verify proper operation of the ZW215FP, view the valve during normal operation and check the valve for minimum suction pressure setting. Adjustments can be made at anytime.

⚠ **WARNING:** Cancer and Reproductive Harm - www.P65Warnings.ca.gov
 ⚠ **ADVERTENCIA:** Cáncer y daño reproductivo - www.P65Warnings.ca.gov
 ⚠ **AVERTISSEMENT:** Cancer et néfastes sur la reproduction - www.P65Warnings.ca.gov



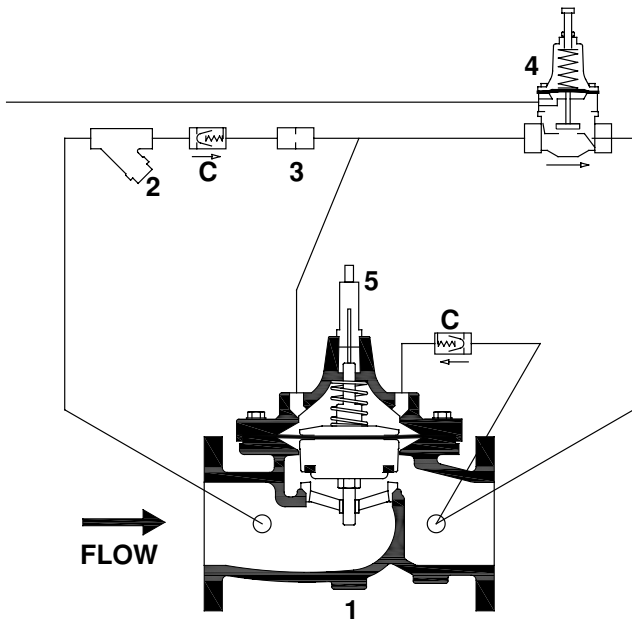

ZW215FPC SCHEMATIC STANDARD COMPONENTS

1. Main Valve
2. SXL "Wye"
3. Restriction Tube Fitting
4. PV-RLF Pressure Relief Valve
5. ZPI Visual Position Indicator

OPTIONAL FEATURES

- C 40XL2 Hydraulic Check w/
Isolation Valve

Operation

The Zurn Wilkins ZW215FP utilizes a pressure relief pilot valve that installs on the discharge side of the control circuitry. The pilot Model PV-RLF is a direct acting, normally closed, spring loaded, diaphragm actuated valve. The operation of the ZW215FP begins with accurately sizing the valve, then fine tuning the control circuitry by adjusting the PV-RLF to open at the desired suction pressure. A sensing line runs externally from the suction side of the pump to the pilot control chamber under the diaphragm. Thus, suction pressure exceeding the preset of the pilot acts to open the pilot valve while the adjustable spring in the pilot seeks to keep it closed. The result is a modulating action in the pilot that is transmitted to the cover of the main valve. This creates a mirror modulation of the diaphragm assembly in the main valve. Suction pressure is maintained within narrow limits regardless of changing flow rates or outlet pressure when supply has decreased below acceptable limits.



Drip Tight Closing Operation

With the use of a three way pilot control, inlet pressure is directed to the cover where the pressure forces the valve closed.



Full Open Operation

Using a three way pilot control, pressure is vented to the outlet from the cover chamber which enables the inlet pressure to open the main valve.

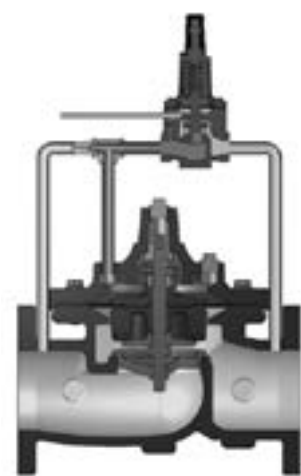

Modulating Action

Utilizing a Wilkins modulating control system, pressure changes to the cover can be controlled, allowing the valve to throttle and compensate for changes.

Flow Characteristics

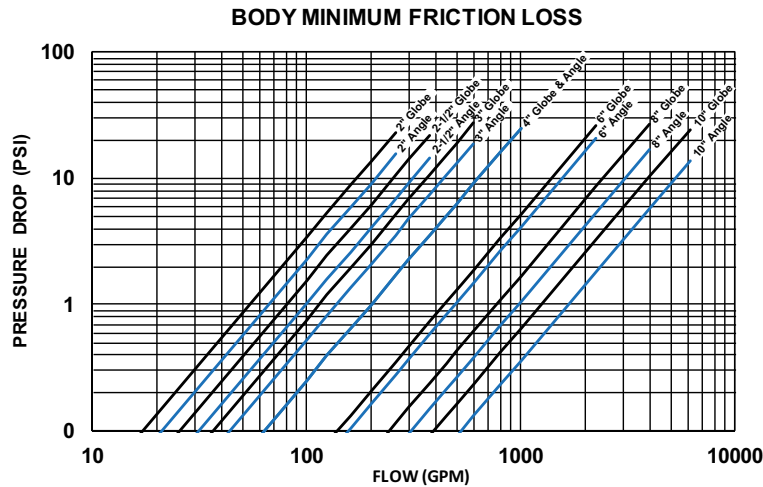

Maintenance Instructions

MAINTENANCE

(Main Valve)

In addition to complying with NFPA 25 every five years, scheduled preventative maintenance and inspection is highly recommended. ZURN WILKINS recommends annual inspection of valves for leaks and proper operation. It is also recommended that a repair kit with a new diaphragm, disc, and o-rings be on hand before work begins.

DISASSEMBLY

Warning: With the ability to perform inspections and maintenance without removal from the system, It is very important that all shut off valves be closed and all pressure relieved in the valve before beginning disassembly. Failure to do so can result in personnel injury or equipment damage.

1. With all pressure removed from the valve, begin slowly loosening flare fitting in the pilot system until residual pressure is removed from cover. After excess pressure has been relieved begin removal of pilot tubing to cover.
2. Begin loosening cover bolts and remove cover lifting up to slide cover bushing off plunger shaft. For valves larger than 6" it is recommended that lifting lugs and a hoist be used due to excessive weight of the larger covers.
3. Once the cover is removed the plunger spring and spring washer can be removed. Then remove the diaphragm assembly by grabbing the stem or lifting from two sides of the diaphragm. Be sure to lift straight up to avoid binding the stem in the seat bushing, as damage can occur. NOTE: Again with the larger size valves 6" and up it is recommended that a lifting lug and hoist be used to remove larger plunger assemblies.
4. Place diaphragm assembly in a vise with the bottom hex secured. Remove the stem nut and inspect threads for damage, corrosion, or pitting.
5. After inspecting the stem and removing the nut the diaphragm

assembly can be dismantled. When disassembling be sure to clean, inspect, and save all components. Replace any damaged components as necessary.

6. Next, clean and inspect the seat inside the main valve body. If excessive water deposits are present, fine grit sand paper can be used to clean. The seat is designed to be removed, but typically does not require removal. If damage is noticeable or seat is excessively worn, replace the seat before reassembly.

7. Refer to www.zurn.com to find ZW205 instruction sheet for more detailed instructions for disassembly and reassembly of main valve.

REASSEMBLY

Prior to reassembly clean, inspect, and replace any parts as needed.

1. Using a vise, diaphragm assembly can be held and assembled in the reverse order as disassembly section.
2. Clamp valve stem hex in a vise and reassemble diaphragm assembly. Make sure to **center diaphragm** on plunger before placing diaphragm disc. Refer to ZW205 instruction sheet at www.zurn.com or call product support 877-222-5356 for further assistance.
3. Once diaphragm assembly is assembled, gently lower stem into seat guide. Rotate diaphragm as needed until bolt holes line up with body bolt holes.
4. Install spring then the cover. Tighten bolts in a cross pattern. Be careful not to pinch the diaphragm when inserting and tightening cover bolts.
5. Reattach pilot assembly and tighten all bolts and fitting as needed.

Maintenance (PV-RLF Valve)

The PV-RLF Pressure Relief Valve may be installed in any position. The flow direction is shown below. Flow goes from the narrow side to the wide side of the cast body.

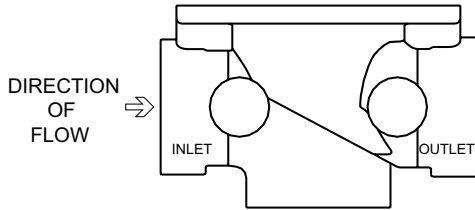

Disassembly

Prior to disassembly, relieve all pressure in pilot system and then remove the PV-RLF.

1. Secure valve body and turn the adjustment screw all the way out.
2. Next remove 8 socket head screws around the pilot bell using a 5/32" hex key. Remove the bell, the spring, and 2 spring discs.
3. Remove the spacer and remove small gasket from the bottom of the spacer. Use a 12mm socket or adjustable wrench on the diaphragm and plunger nuts to disassemble the plunger/diaphragm assembly. Unscrew one end of the stem.
4. At this point slide the plunger/diaphragm assembly out of the valve spacer.
5. Use soft jaws or a towel and pliers to clamp the stem. Be careful not to scratch the stem as this is an o-ring surface. Use an adjustable wrench on the opposite nut to remove the remaining plunger/diaphragm assembly.
6. The parts removed from the disassembled diaphragm and plunger assembly are a plunger, small washer, 2 o-rings, 2 nuts, a medium washer, a large washer, diaphragm, and lock washer.
7. Use a small pin or nail to carefully remove the o-ring on the inside through hole of the spacer.
8. After complete disassembly thoroughly clean and inspect all components before reassembly. Replace parts as necessary after inspection.
9. The pilot seat generally does not need to be removed, but if after inspection it requires replacement it can be removed with a 1-1/16" socket.

PV-RLF Valve

Reassembly

Reassembly of the PV-RLF is the reverse of disassembly.

1. Carefully install a new o-ring in the through hole of the spacer.
2. Place the medium washer (with round outer edge toward the diaphragm) on the side of the stem with the chamfered tip.
3. Follow the washer by putting on a new o-ring, new diaphragm, large washer (with the inner step against the diaphragm), lock washer, and 5/16" (chamfered side away from diaphragm) nut then hand tighten.
4. Slide the stem through the spacer with the diaphragm assembly on the spacer side with a circular groove on the top surface.
5. On the other side of the stem place the small washer, o-ring, plunger (with the rubber facing away from the spacer), and nut.

6. Use adjustable wrenches to tighten the plunger and diaphragm nuts.
7. Place small gasket on bottom of valve spacer.
8. Install the plunger assembly on to the body with the plunger sitting on the valve seat. The small rubber gasket on the plunger side of the spacer must cover the sensing hole on the pilot body.
9. Place a spring disk on the stem, then the spring, another spring disk and bell.
10. Insert socket head cap screws into pilot bell holes and thread into valve body. Place model tag on the four screws that straddle the body inlet. Tighten all screws in a cross pattern.
11. Install adjusting screw by hand with jam nut. Set valve once reinstalled into pilotry system. Refer to "Start-up" section on page one for proper setting of relief pilot. For further assistance or ordering replacement parts go to www.zurn.com or call product support 877-222-5356.

Table 1

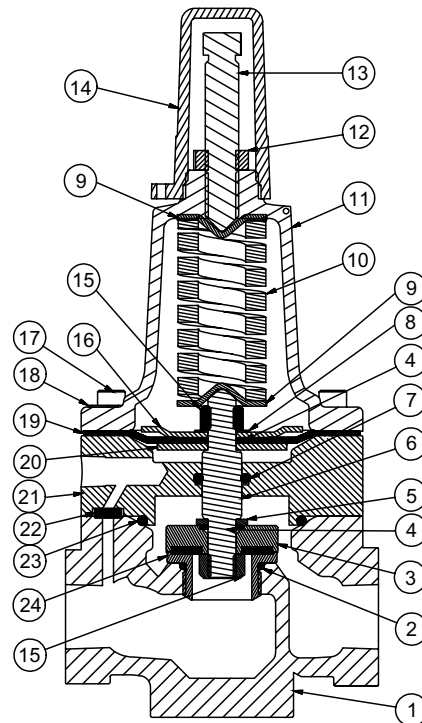

ITEM	DESCRIPTION
1	1/2" Relief Body
2	O-ring Buna Nitrile, NSF Listed
3	Relief Plunger Assy.
4	Diaphragm O-ring
5	5/16" Flat Washer
6	Relief Pilot Stem
7	O-ring, Buna Nitrile, NSF Listed
8	5/16" Internal Tooth Lock Washer
9	Spring Disc
10	Spring
11	Pilot Bell
12	3x8-16 Jam Hex Nut

ITEM	DESCRIPTION
13	3/8-16 Adjustment Bolt
14	Adjustment Cover
15	5/16-18 Diaphragm Nut
16	Relief Pilot Upper Diaphragm Disc,SS
17	10-32 X 1-1/2" Skt Hd Cap Screw, SS
18	Tag
19	Diaphragm
20	Relief Pilot Lower Diaphragm Washer
21	Relief Pilot Spacer
22	Sensing Hole Gasket
23	O-ring, Buna Nitrile, NSF Listed
24	Relief Pilot Seat

ZURN WILKINS