



# Z5738.235.00

"The Small Pint<sup>®</sup>" 1/8 gpf, EcoVantage<sup>®</sup>,  
Ultra Low Consumption, Urinal System

TAG \_\_\_\_\_



Z5738.235.00 Series

### Z5738.235.00 Series

- Zurn One ultra low consumption urinal system designed for optimal performance between Zurn fixture and Zurn flush valve to save water while exceeding industry performance standards
- 1/8 gallons per flush [0.5 Liters per flush]
- Vitreous china
- High efficiency washout flushing action
- Over 88% water savings over standard 1.0 gpf [4.0 Lpf] system
- Sensor operated battery powered actuation
- 3/4" top spud
- 2" I.P.S. outlet flange and rubber gasket with integral trap
- 14" extended rim for handicap compliance when installed at proper height
- Vandal resistant outlet strainer included
- Shipping Weight: 39 lbs.

### ENGINEERING SPECIFICATION:

**Z5738.235.00 EcoVantage<sup>®</sup> Sensor Operated High Efficiency Urinal (HEU) System** - System comes complete with exposed ZER6003AV-ULF high efficiency flushometer valve with sensor operated battery powered actuation and vitreous china urinal. The system is designed to perform to industry standards with as little as 1/8th gallon per flush. The valve is an exposed, quiet diaphragm-type, chrome plated flushometer valve with a polished exterior. Complete with Zurn's AquaVantage<sup>®</sup> TPE, chloramine resistant, triple filtered bypass. This valve incorporates a 6VDC motor actuator, a battery powered automatic sensor, high impact resistant polycarbonate housing and chrome plated ABS cover with manual over-ride push button, high back pressure vacuum breaker, one piece hex coupling nut, adjustable tailpiece, spud coupling and flange for top spud connection. Control stop has internal siphon-guard protection, vandal resistant stop cap, sweat solder kit, and a cast wall flange with set screw. Vitreous china urinal is supplied with 3/4" top spud, 2" outlet connection, vandal resistant outlet strainer and retrofit hanger bracket.

This space is for Architectural/engineering Approval

*These dimensions and specifications are subject to change without notice.*

Fixture dimensions meet ANSI/ASME standards A112.19.2 and CAN/CSA B45 requirements.

Meets the American Disabilities Guidelines and ANSI A117.1 requirements when urinal is installed 17" [432 mm] from finished floor.



www.GreenSpec.com

ZURN INDUSTRIES, LLC. ♦ COMMERCIAL BRASS OPERATION ♦ 5900 ELWIN BUCHANAN DRIVE ♦ SANFORD NC 27330

Phone: 1-800-997-3876 ♦ Fax: 919-775-3541 ♦ World Wide Web: www.zurn.com

In Canada: ZURN INDUSTRIES LIMITED ♦ 3544 Nashua Drive ♦ Mississauga, Ontario L4V1L2 ♦ Phone: 905-405-8272 Fax: 905-405-1292

EcoVantage<sup>®</sup> and "The Pint<sup>®</sup>" are a registered trademarks of Zurn Industries, LLC.



# Z5738.235.00

"The Small Pint®" 1/8 gpf, EcoVantage®, Ultra Low Consumption, Urinal System Rough-In TAG \_\_\_\_\_

Rough-in dimensions for Z5738.235.00 Series  
 \*Z5738 with top spud

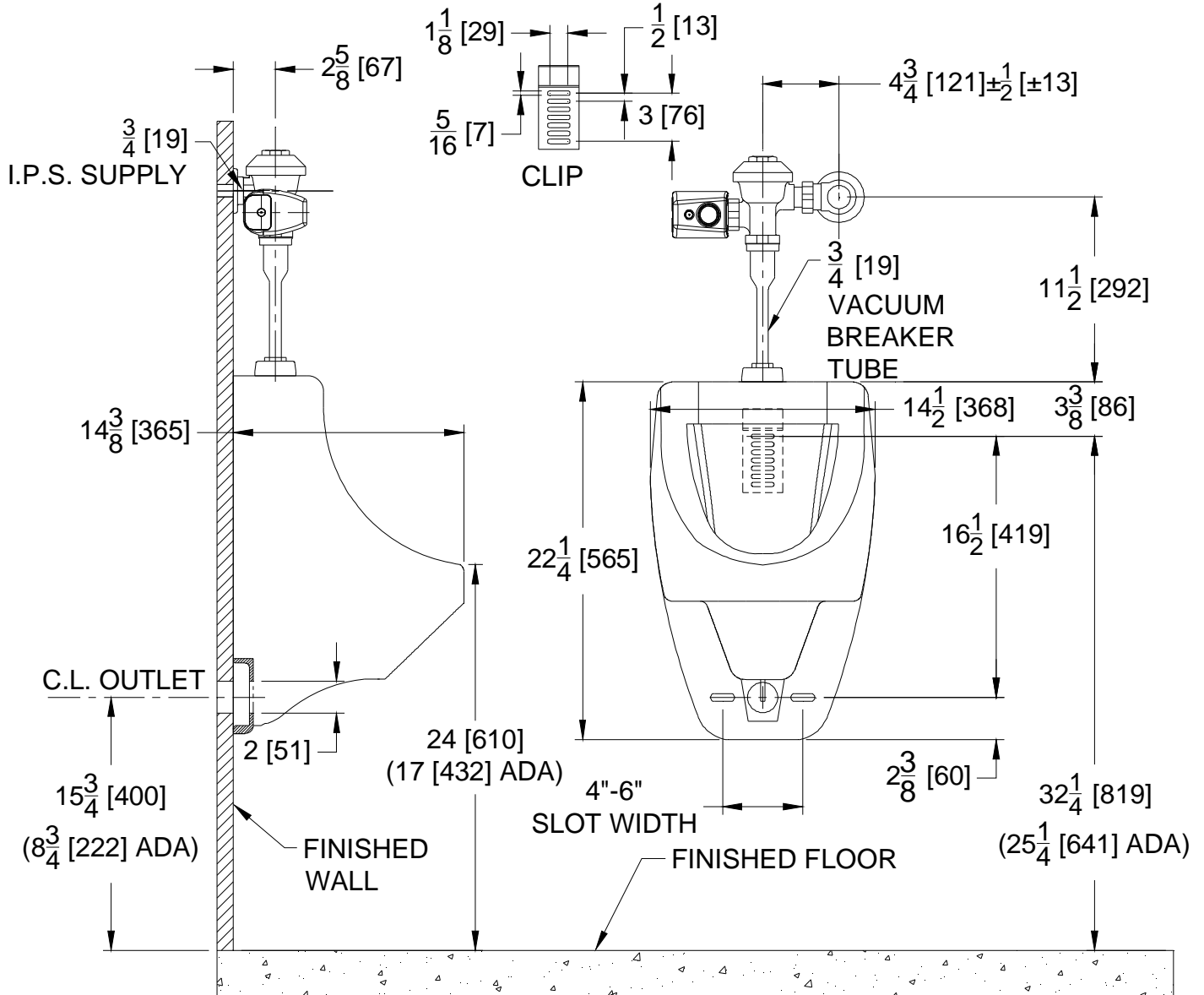

These dimensions and specifications are subject to change without notice.

Fixture dimensions meet ANSI/ASME standard A112.19.2 and CAN/CSA B45 requirements.

Meets the American Disabilities Guidelines and ANSI A117.1 requirements when urinal is installed 17" [432 mm] from finished floor.



www.GreenSpec.com

ZURN INDUSTRIES, LLC. ♦ COMMERCIAL BRASS OPERATION ♦ 5900 ELWIN BUCHANAN DRIVE ♦ SANFORD NC 27330

Phone: 1-800-997-3876 ♦ Fax: 919-775-3541 ♦ World Wide Web: www.zurn.com

In Canada: ZURN INDUSTRIES LIMITED ♦ 3544 Nashua Drive ♦ Mississauga, Ontario L4V1L2 ♦ Phone: 905-405-8272 Fax: 905-405-1292

EcoVantage® and "The Pint®" are a registered trademarks of Zurn Industries, LLC.