



LABORATORY FAUCET - DOUBLE

Z826A3-XL

TAG _____



Engineering Specifications: Zurn AquaSpec® Z826A3-XL

Polished chrome-plated double laboratory faucet with integral shank, quarter turn ceramic disc cartridges and a 3-1/2" [89mm] centerline rigid or swing gooseneck spout. Unit is furnished with a 2.2 GPM [8.3 L] pressure compensating aerator (complying with ANSI A112.18.1 Standard for flow), 2" [51mm] vandal-resistant color-coded metal dome lever handles, mounting hardware and stainless steel flex connection hoses.

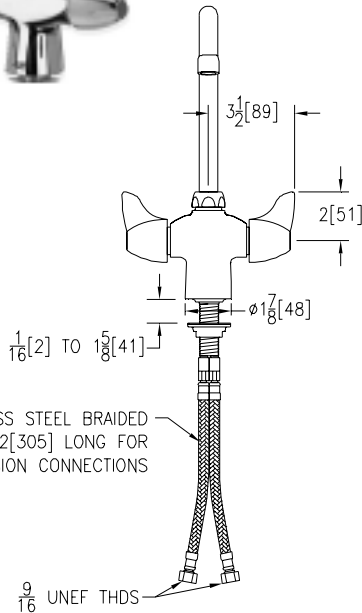

STAINLESS STEEL BRAIDED HOSE 12[305] LONG FOR 3/8 COMPRESSION CONNECTIONS

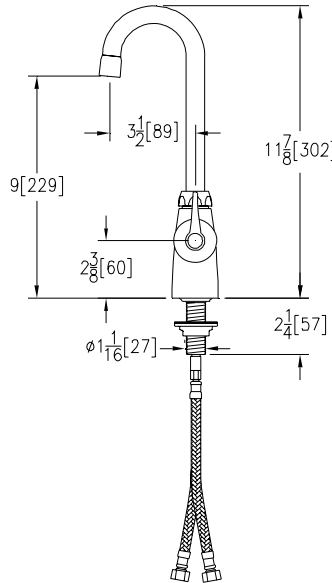

Zurn Lead Compliant* "XL" products are a line of durable, high quality brass faucets and fixtures that are designed and manufactured to comply with state laws and local codes that mandate lead content levels. Zurn "XL" products are manufactured with *not more than 0.25% lead content when used with respect to wetted surfaces of pipes and pipe fittings, plumbing fitting and fixtures: California Health & Safety Code § 116875; Vermont 9 VCA § 2470h

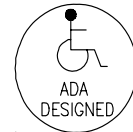

Note: All dimensions are for reference only. Do not use for pre-plumbing.

OPTIONAL ACCESSORIES

Suffix	Description
___-AR	Anti-Rotation Pins
___-CST	Copper Supply Tubes
___-FC	2.0 GPM [7.6 L] Laminar Flow Control in Base of Spout
___-G	1-1/4" [32mm] Grid Strainer Drain
___-HCT	Hot/Cold Text Indexes
___-MY	Mixing Yoke Assembly Instead of Copper Supplies
___-PT	1-1/4" [32mm] Cast Brass P-Trap with a 7-1/2" [191mm] Long 17-Gauge Wall Bend
___-140	140° Restricted Swing Spout
___-2F	2.2 GPM [8.3 L] Vandal-Resistant Pressure Compensating Female Aerator
___-3F	0.5 GPM [1.9 L] Vandal-Resistant Pressure Compensating Female Spray Outlet
___-4F	2.2 GPM [8.3 L] Vandal-Resistant Pressure Compensating Female Laminar Flow Outlet
___-7F	1.0 GPM [3.8L] Pressure Compensating Female Spray Outlet
___-16F	1.0 GPM [3.8L] Vandal-Resistant Pressure Compensating Female Spray Outlet
___-17F	1.5 GPM [5.7L] Vandal-Resistant Pressure Compensating Female Aerator
___-18FH	18" [457mm] S.S. Braided Flex Hoses
___-18F	1.5 GPM [5.7L] Vandal-Resistant Pressure Compensating Female Laminar Flow Outlet
___-19F	1.5 GPM [5.7 L] Anti-Microbial Pressure Compensating Female Laminar Flow Outlet
___-21F	1.0 GPM [3.8L] Pressure Compensating Female Laminar Flow Outlet
___-22F	1.0 GPM [3.8L] Pressure Compensating Vandal-Resistant Female Laminar Flow Outlet
___-23F	1.5 GPM [5.7L] Pressure Compensating Female Aerator

ZURN INDUSTRIES, LLC ♦ COMMERCIAL BRASS OPERATION ♦ 2640 SOUTH WORK STREET ♦ FALCONER NY 14733

Phone: 1-800-997-3876 ♦ Fax: 1-919-775-3541 ♦ www.zurn.com

In Canada: ZURN INDUSTRIES LIMITED ♦ 3544 Nashua Drive ♦ Mississauga, Ontario L4V1L2 ♦ Phone: 905/405-8272 Fax: 905/405-1292