



Z1284

CONCRETE FLOOR SUPPORTED WATER CLOSET CARRIER

SPECIFICATION SHEET

TAG _____

Dimensional Data (inches and [mm]) are Subject to Manufacturing Tolerances and Change Without Notice

NOTE:
FITS IN 2 X 8 [51 X 203]
STUD WALL

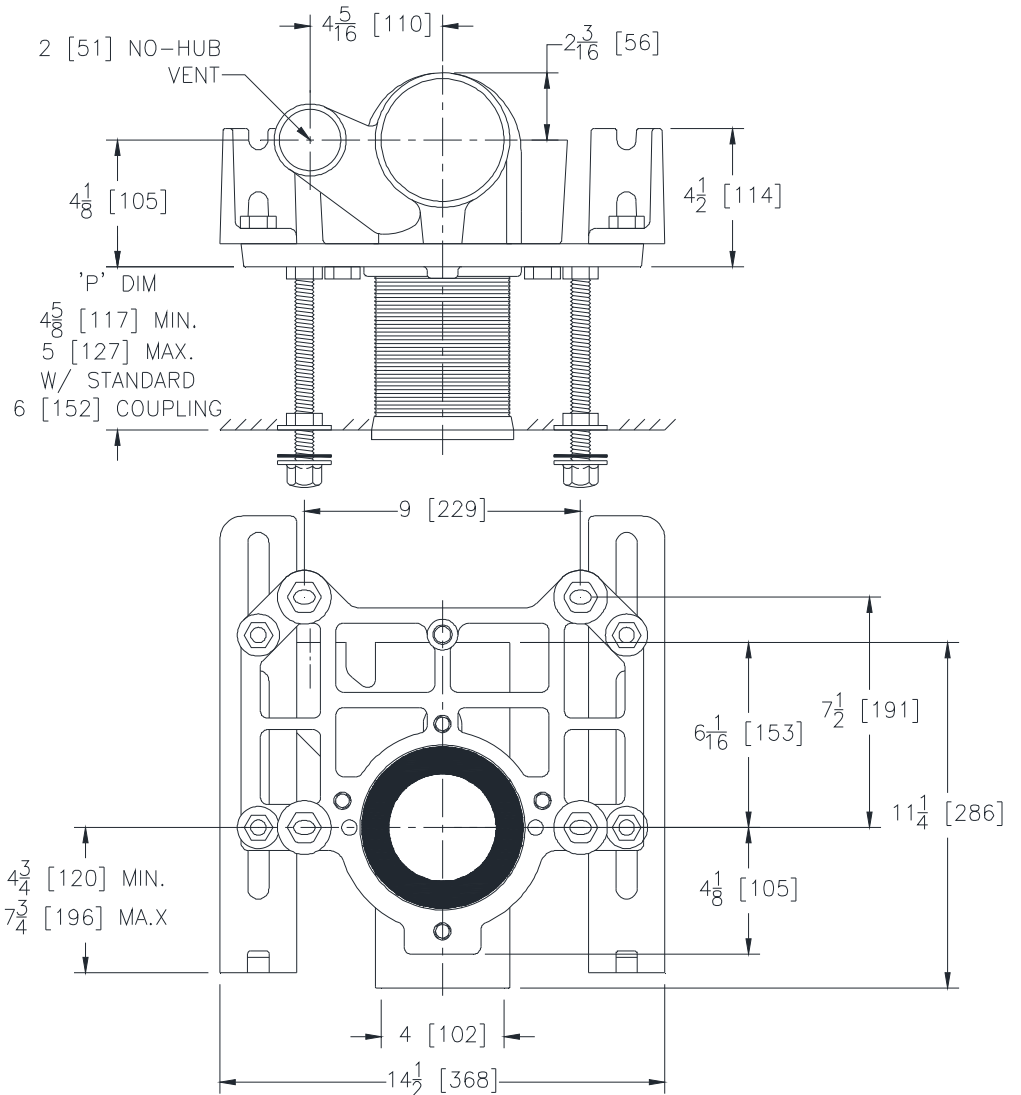

Product No.	Approx. Wt. Lbs.[kg]
Z1284-N4	40 [64]

ENGINEERING SPECIFICATION: ZURN Z1284

4" [102mm] Residential water closet support system. Complete with Dura-Coated cast iron 4" [102mm] No-Hub fitting with 2" [51mm] Vent, support feet, corrosion resistant ABS coupling, fixture bolts and trim, and bonded "Neo-Seal" gasket.

PREFIXES

____ Z Dura-Coated Cast Iron System*

SUFFIXES

____ -X4 4 [102] Carrier Foot Extension

* Regularly furnished unless otherwise specified.

Zurn Industries, LLC | Specification Drainage Operation
 1801 Pittsburgh Avenue, Erie, PA U.S.A. 16502 · Ph. 855-663-9876, Fax 814-454-7929
 In Canada | Zurn Industries Limited
 3544 Nashua Drive, Mississauga, Ontario L4V 1L2 · Ph. 905-405-8272, Fax 905-405-1292
www.zurn.com

Rev. G
 Date: 09/27/2017
 C.N. No. 137992
 Prod. | Dwg. No. Z1284