



Z415K

BODY ASSEMBLY W/ "TYPE K" STRAINER

SPECIFICATION SHEET

TAG _____

Design and Dimensional Data (inches and [mm]) are Subject to Manufacturing Tolerances and Change Without Notice

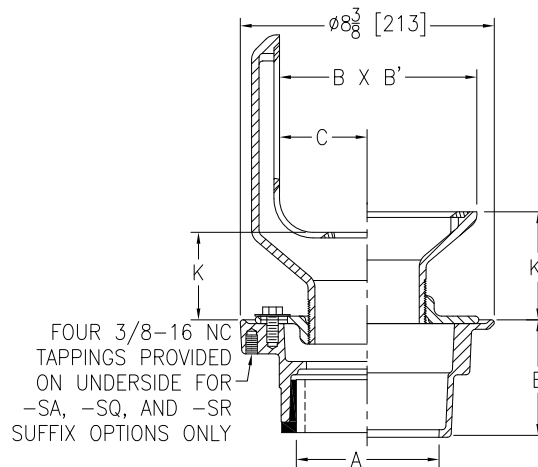

Strainer Designation	Dimension in Inches [mm]							Approx. Wt. Lbs. [kg]	Strainer Open Area Sq. In. [cm ²]
	A - Pipe Size	B X B'	C	K		K'			
				Min.	Max.	Min.	Max.		
-5K	2,3,4 [51,76,102]	3-3/4 x 5 [102 x 127]	1-7/32 [31]	1 [25]	2 [51]	1-3/4 [44]	2-3/4 [70]	18 [8]	11 [71]
-7K	2,3,4 [51,76,102]	6-5/8 x 7 [178 x 178]	2-15/16 [75]	2-3/16 [56]	3-3/8 [86]	2-7/8 [73]	4-1/8 [105]	25 [11]	29 [187]

ENGINEERING SPECIFICATION: ZURN ZN415K

Floor and shower drain, Dura-Coated cast iron body with bottom outlet, combination invertible membrane clamp and adjustable collar with seepage slots and "TYPE K" polished, nickel bronze, angular, light-duty strainer.

OPTIONS (Check/specify appropriate options)

PIPE SIZE	(Specify size/type)	OUTLET	'E' BODY HT. DIM.
2 [51]	___ IP	Threaded	2-7/16 [62]
3 [76]	___ IP	Threaded	2-3/4 [70]
4 [102]	___ IP	Threaded	2-13/16 [71]
2,3,4 [51,76,102]	___ NH	No-Hub	3-13/16 [97]
2,3,4 [51,76,102]	___ NL	Neo-Loc	3-7/8 [98]

PREFIXES

- ___ ZB D.C.C.I. Body Assembly w/ Polished Bronze Top
- ___ ZN D.C.C.I. Body Assembly w/ Polished Nickel Bronze Top*

SUFFIXES

- | | |
|---|---|
| ___ -AR Acid Resisting Epoxy Coated Cast Iron | ___ -U 1-3 [25-76] High Extension Adapter |
| ___ -G Galvanized Cast Iron | ___ -V Backwater Valve |
| ___ -P Trap Primer Connection (Specify 1/2 [13] or 3/4 [19]) | ___ -VP Vandal-Proof Secured Top |
| ___ -SA Stabilizer Assembly (See Z1035) | ___ -Y Sediment Bucket |
| ___ -SQ Stabilizer Q-Deck (See Z1035-Q) | ___ -90 90° Threaded Side Outlet Body Assembly (2,3 [51,76] Only) |
| ___ -SR Stabilizer Ring | |
| ___ -TC Neo-loc Test Cap Gasket (2,3,4 [51,76,102] NL Bottom Outlet Only) | |

* Regularly furnished unless otherwise specified.

- ⚠ **WARNING:** Cancer and Reproductive Harm - www.P65Warnings.ca.gov
- ⚠ **ADVERTENCIA:** Cáncer y daño reproductivo - www.P65Warnings.ca.gov
- ⚠ **AVERTISSEMENT:** Cancer et effets néfastes sur la reproduction - www.P65Warnings.ca.gov

Zurn Industries, LLC | Specification Drainage Operation
1801 Pittsburgh Avenue, Erie, PA USA 16502, Ph. 855.663.9876

In Canada | Zurn Industries Limited
7900 Goreway Drive, Unit 10, Brampton, Ontario L6T 5W6, Ph. 877.892.5216

www.zurn.com

Rev. N
Date: 01/05/23
C.N. No. 144898
Patent zurn.com/patents
Prod. | Dwg. No. Z415K