



**PRE-RINSE**  
**Z800X0-PR1**  
**TAG \_\_\_\_\_**



**Engineering Specifications: Zurn AquaSpec® Z800X0-PR1**

Pre-rinse hose assembly furnished with a 24" [610mm] riser with a 36" [914mm] stainless steel spring hose, a self-closing 1.6 GPM @ 60 psi (6.1 l/min. @ 400 kPa) pre-rinse hand held valve with an insulated 6" [152mm] handle, a stay open clip, a protective bumper spray head, a pipe support and hook.

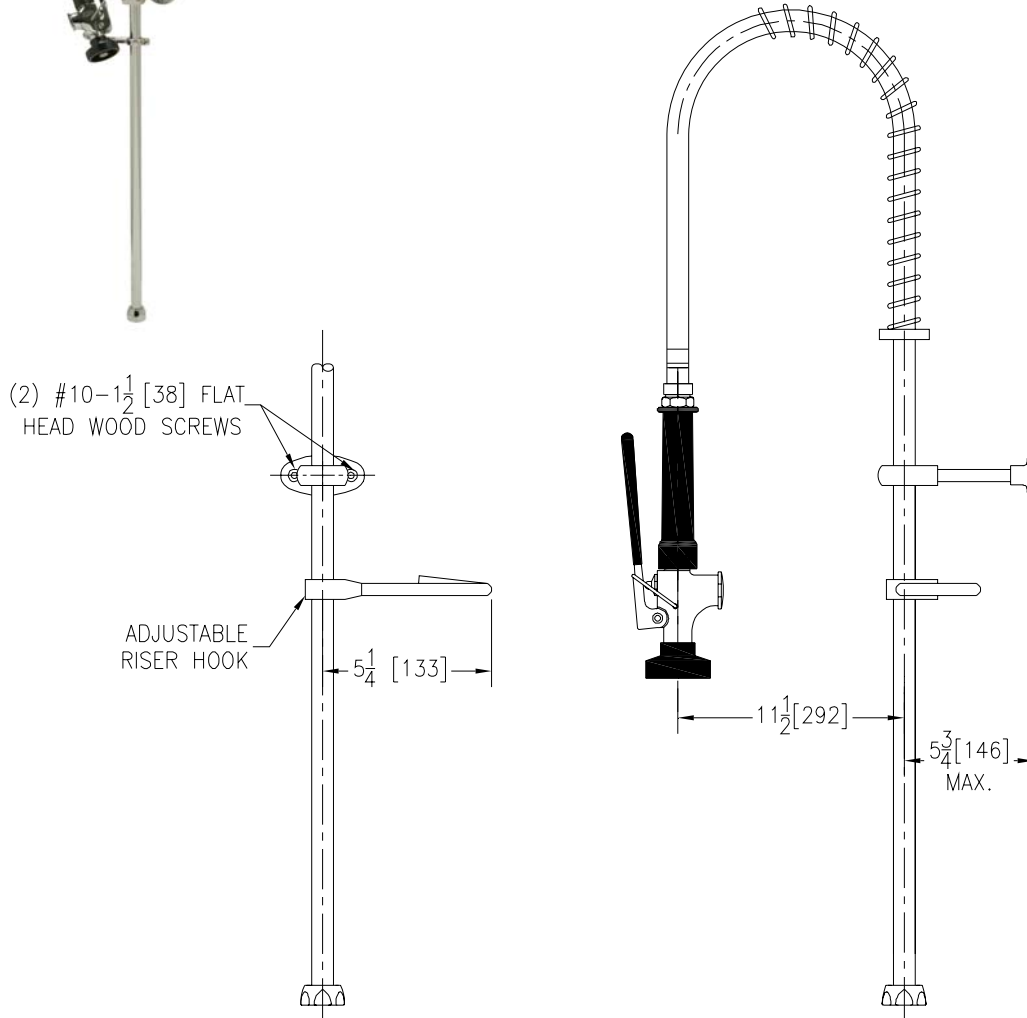

Note: All dimensions are for reference only. Do not use for pre-plumbing

**OPTIONAL ACCESSORIES**

Suffix	Description
— -PR2	Pre-rinse with Angle Spray Head, Rubber Bumper Spray Outlet and Self-closing Valve
— -PR3	Pre-rinse with Angled Aerated Outlet and Self-closing Valve
— -38	24" [61mm] Riser Tube with 3/8" [10mm] NPT Connection for use with Adapta Faucet

ZURN INDUSTRIES, LLC ♦ COMMERCIAL BRASS OPERATION ♦ 2640 SOUTH WORK STREET ♦ FALCONER NY 14733

Phone: 1-800-997-3876 ♦ Fax: 1-919-775-3541 ♦ www.zurn.com

In Canada: ZURN INDUSTRIES LIMITED ♦ 3544 Nashua Drive ♦ Mississauga, Ontario L4V1L2 ♦ Phone: 905/405-8272 Fax: 905/405-1292