

Engineering Specifications: Zurn AquaSpec® Z831J1-HS

Polished chrome-plated widespread with adjustable centers from 6" [152mm] to 20" [508mm], a 9-1/2" [241mm] tubular brass swing spout and quarter turn ceramic disc cartridges. Unit is furnished with a hose and spray, a 2.2 GPM [8.3 L] pressure compensating aerator (complying with ANSI A112.18.1 Standard for flow), 2-1/2" [64mm] vandal-resistant color-coded metal lever handles, mounting hardware and 1/2" NPSM coupling nuts for standard lavatory risers. Widespread accommodates installations up to 1-1/2" [38mm] thick.

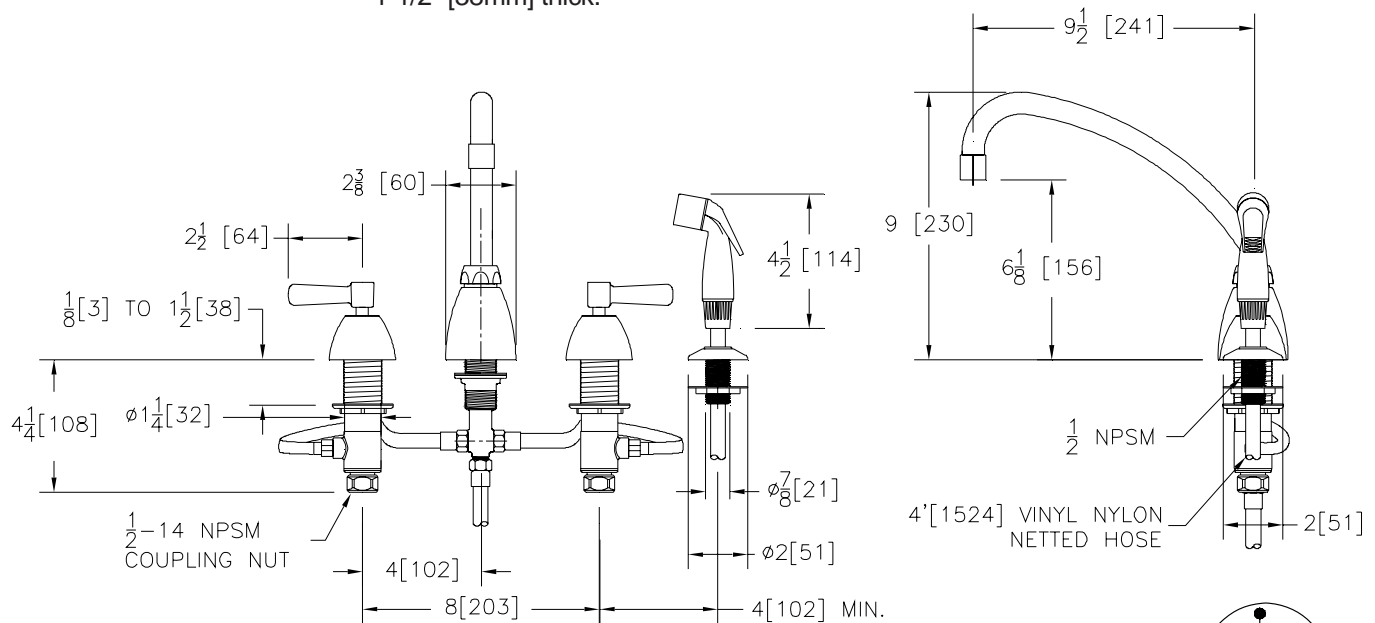

Note: All dimensions are for reference only. Do not use for pre-plumbing



OPTIONAL ACCESSORIES

Suffix	Description
___ -CWO	Cold Water Only
___ -G	1-1/4" [32mm] Grid Strainer Drain
___ -GH	1-1/4" [32mm] Offset Handicap Grid Drain
___ -HCT	Hot/Cold Text Indexes
___ -ICT	Inter-connecting Copper Supply Tubes for 8" In-line Centers
___ -PT	1-1/4" [32mm] Cast Brass P-Trap with a 7-1/2" [191mm] Long 17-Gauge Wall Bend
___ -2F	2.2 GPM [8.3 L] Vandal-Resistant Pressure Compensating Female Aerator
___ -3F	0.5 GPM [1.9 L] Vandal-Resistant Pressure Compensating Female Aerator
___ -4F	2.2 GPM [8.3 L] Vandal-Resistant Pressure Compensating Female Laminar Flow
___ -5F	2.0 GPM [7.6 L] Female Spray Outlet
___ -7F	1.0 GPM [3.8 L] Pressure Compensating Female Spray Outlet
___ -16F	1.0 GPM [3.8 L] Vandal Resistant Pressure Compensating Female Spray Outlet
___ -17F	1.5 GPM [5.7 L] Vandal Resistant Pressure Compensating Female Aerator
___ -18F	1.5 GPM [5.7 L] Vandal Resistant Pressure Compensating Female Laminar Flow
___ -19F	1.5 GPM [5.7 L] Anti-Microbial Pressure Compensating Female Laminar Flow Outlet
___ -20F	1.0 GPM [3.8L] Vandal-Resistant Pressure Compensating Anti-Microbial Female Laminar Flow Outlet
___ -21F	1.0 GPM [3.8L] Female Laminar Flow Outlet
___ -22F	1.0 GPM [3.8L] Vandal-Resistant Female Laminar Flow Outlet

ZURN INDUSTRIES, LLC ♦ COMMERCIAL BRASS OPERATION ♦ 2640 SOUTH WORK STREET ♦ FALCONER NY 14733

Phone: 1-716-665-1132 ♦ Fax: 1-716-665-1135 ♦ World Wide Web: www.zurn.com

In Canada: ZURN INDUSTRIES LIMITED ♦ 3544 Nashua Drive ♦ Mississauga, Ontario L4V1L2 ♦ Phone: 905/405-8272 Fax: 905/405-1292