

Dimensional Data (inches and [mm]) are Subject to Manufacturing Tolerances and Change Without Notice

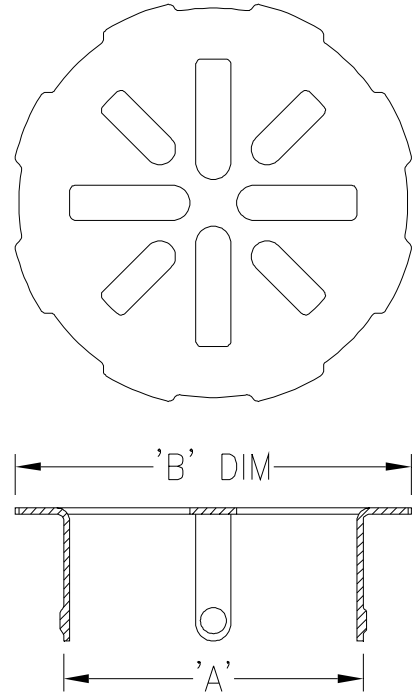

Product	'A' Connections	'B' Dimensions
___ FD-2390-SS2	2 [51] Press-In	2 1/2 [64]
___ FD-2390-SS3	3 [76] Press-In	4 [102]
___ FD-2390-SS4	4 [102] Press-In	5 [127]

FD2390 Snap-In Grate

This polished stainless steel insert floor drain fits firmly on the inside diameter of all types of pipe 2 [51] through 4 [102].

Typical Installation

