



PRE-RINSE UNIT

G62739

TAG _____

Engineering Specification: Zurn AquaSpec® G62739

Self-closing 1.6 GPM @ 60 psi (6.1 l/min. @ 400 kPa) pre-rinse valve with a stay open ring and rubber bumper spray head. Unit has a 3/4-14 UNS threaded male inlet. Fits all major manufacturers.

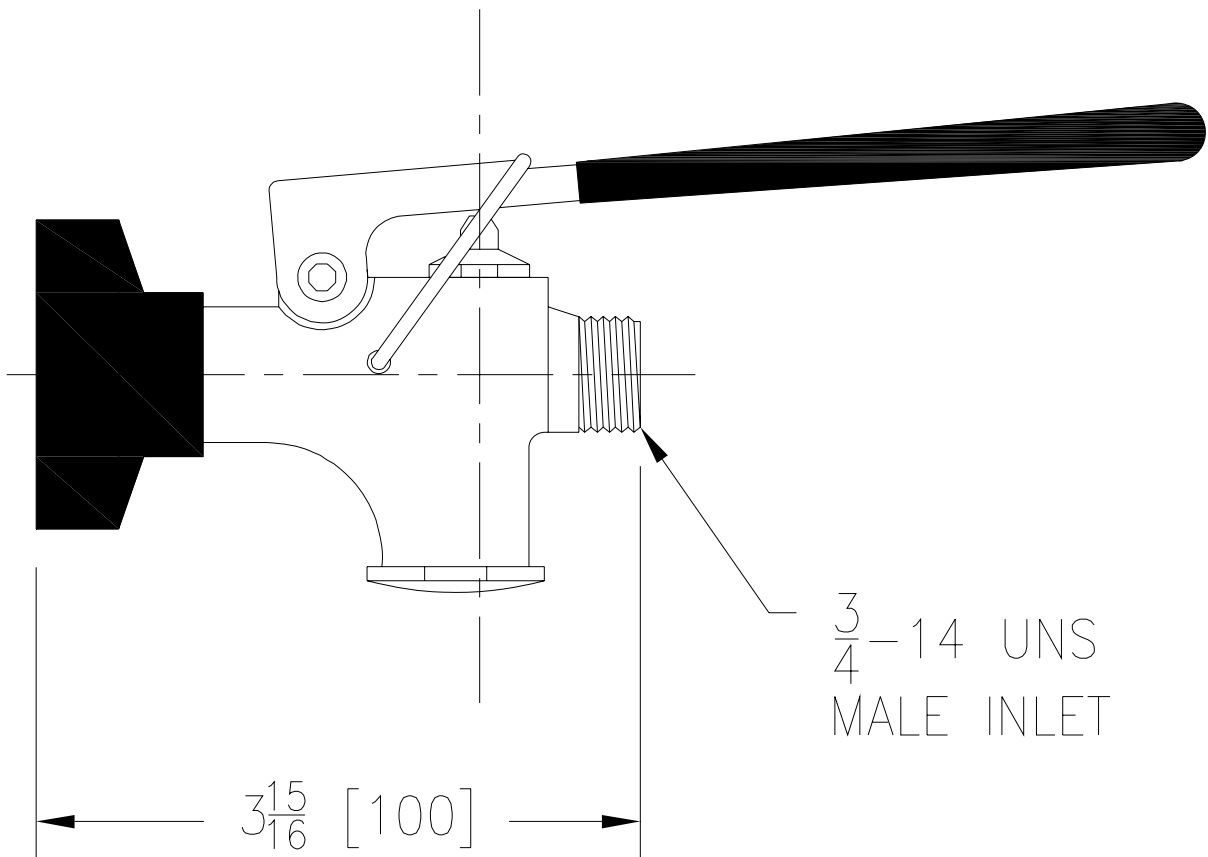

Note: All dimensions are for reference only. Do not use for pre-plumbing.

OPTIONAL ACCESSORIES

No options required.

ZURN INDUSTRIES, LLC ♦ COMMERCIAL BRASS OPERATION ♦ 2640 SOUTH WORK STREET ♦ FALCONER NY 14733

Phone: 1-800-997-3876 ♦ Fax: 1-919-775-3541 ♦ www.zurn.com

In Canada: ZURN INDUSTRIES LIMITED ♦ 3544 Nashua Drive ♦ Mississauga, Ontario L4V1L2 ♦ Phone: 905/405-8272 Fax: 905/405-1292