

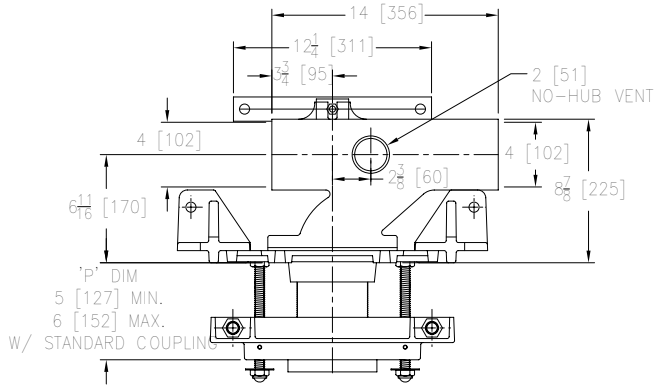

# Z1203-N-XB

BARIATRIC CARRIER - 1000 LB. [454 KG.]  
ADJUSTABLE HORIZONTAL SIPHON JET NO-HUB

Design and Dimensional Data (inches and [ mm ]) are Subject to Manufacturing Tolerances and Change Without Notice



Product Number	Approx. Wt. Lbs. [kg]
Z1203-NL4-XB	107 [46]
Z1203-NR4-XB	

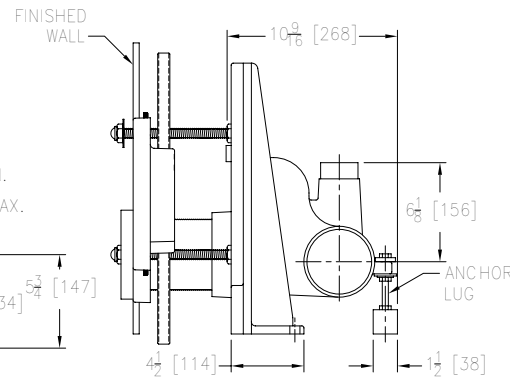
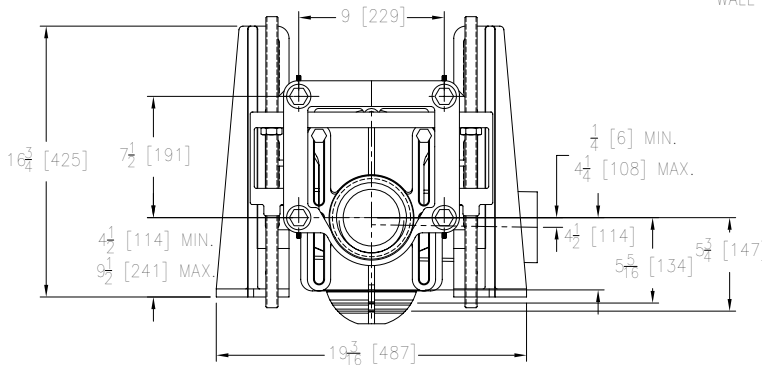

\* PULL-OUT FORCES ARE CALCULATED VALUES, WITH STANDARD COUPLING ASSEMBLY. NO SAFETY FACTOR HAS BEEN APPLIED.

### ENGINEERING SPECIFICATION: ZURN Z1203-N( )-XB

Adjustable, horizontal siphon jet water closet "Rigid System" with 4 [102] No-Hub connections, rated for a 1000-Lb. [454 kg] maximum static load. Complete with Dura-Coated cast iron right hand or left hand main fitting, with 2 [51] vent, adjustable gasketed faceplate, floor mounted foot supports, stud support / finishing frame, corrosion resistant adjustable cast iron coupling, fixture bolts, trim, and stud protectors. Complete with rear anchor tie down and bonded "Neo-Seal" gasket. Carrier complies with all applicable requirements of ASME A112.6.1M up to a 1000-Lb.[454-kg.] load.

### OPTIONS (Check/specify appropriate options)

- \_\_\_ Z1203-NR4-XB 4 [102] No-Hub Right Hand Inlet with Flow to Left
- \_\_\_ Z1203-NL4-XB 4 [102] No-Hub Left Hand Inlet with Flow to Right

### PREFIXES

- \_\_\_ Z D.C.C.I. System with Zurn "ZZ" Adjustable Coupling\*
- \_\_\_ ZQ D.C.C.I. System with NPT Faceplate, Non-Adjustable Coupling

### SUFFIXES

- \_\_\_ -BC Back Cleanout
- \_\_\_ -CV Closed Vent (Use only when local codes allow)
- \_\_\_ -G Galvanized Cast Iron
- \_\_\_ -T Threaded Connection
- \_\_\_ -VP Vandal-Proof Trim
- \_\_\_ -29 Mechanical Test Cap Assembly
- \_\_\_ -50 Flush Valve Supply Support for Water Closets
- \_\_\_ -61 "ZZ" Coupling Wrench

\* Regularly furnished unless otherwise specified

**⚠ WARNING:** Cancer and Reproductive Harm - [www.P65Warnings.ca.gov](http://www.P65Warnings.ca.gov)

**⚠ ADVERTENCIA:** Cáncer y daño reproductivo - [www.P65Warnings.ca.gov](http://www.P65Warnings.ca.gov)

**⚠ AVERTISSEMENT:** Cancer et effets néfastes sur la reproduction - [www.P65Warnings.ca.gov](http://www.P65Warnings.ca.gov)

### Note:

1. Feet and rear anchor bolted to floor using anchors capable of achieving the specified pull-out force.
2. Min. 'P' Dim. Obtainable=2 [51]
3. Back anchor foot mandatory for secure installation.
4. Floor anchors each must be able to withstand a pull-out force of 750 lbs. [340 kg.]

Zurn Industries, LLC | Specification Drainage Operation  
1801 Pittsburgh Avenue, Erie, PA 16502, Ph. 855.663.9876

In Canada | Zurn Industries Limited  
7900 Goreway Drive, Unit 10, Brampton, Ontario L6T 5W6, Ph. 877.892.5216

[www.zurn.com](http://www.zurn.com)

Rev.	D
Date:	12/30/22
C.N. No.	144897
Patent	<a href="http://zurn.com/patents">zurn.com/patents</a>
Prod.   Dwg. No.	Z1203-N-XB