



4" CENTERSET GOOSENECK Z812J1-XL

TAG _____



Engineering Specifications: Zurn AquaSpec® Z812J1-XL

Polished chrome-plated cast brass faucet body with integral shanks, quarter turn ceramic disc cartridges and a 9-1/2" [241mm] tubular brass swing spout. Unit is furnished with a 2.2 GPM [8.3 L] pressure compensating aerator (complying with ANSIA112.18.1 Standard for flow), 2-1/2" [64mm] vandal-resistant color-coded metal lever handles, mounting hardware and 1/2" NPSM coupling nuts for standard lavatory risers. Zurn Lead Free products (-XL) is the line of durable, high quality brass faucets and fixtures that are designed and manufactured to comply with Section 1417 of the Safe Drinking Water Act (SDWA) which mandates the weighted average lead content of no more than 0.25% of the wetted surface.



*This product should be used with a WaterSense labeled counterpart with a compatible flush volume to ensure that the entire system meets the requirements for water efficiency and performance.

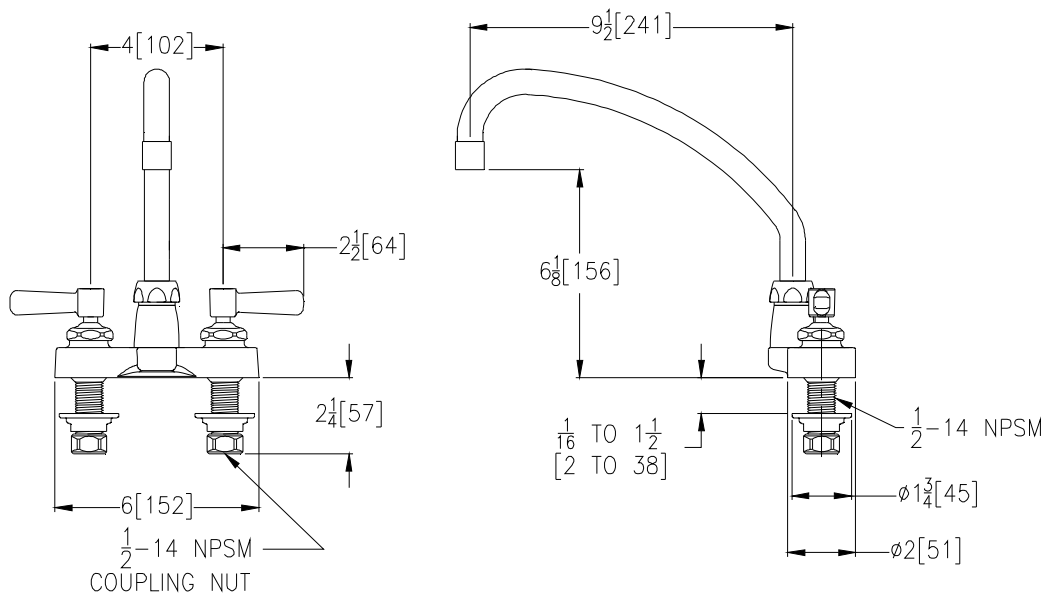

OPTIONAL ACCESSORIES

Note: All dimensions are for reference only. Do not use for pre-plumbing

Suffix	Description
___ -G	1-1/4" [32mm] Grid Strainer Drain
___ -HCT	Hot/Cold Text Indexes
___ -P	1-1/4" [32mm] Pop-up Drain
___ -PT	1-1/4" [32mm] Cast Brass P-Trap with a 7-1/2" [191mm] Long 17-Gauge Wall Bend
___ -2F	2.2 GPM [8.3 L] Vandal-Resistant Pressure Compensating Female Aerator
___ -3F	0.5 GPM [1.9 L] Vandal-Resistant Pressure Compensating Female Spray Outlet
___ -4F	2.2 GPM [8.3 L] Vandal-Resistant Pressure Compensating Female Laminar Flow Outlet
___ -7F*	1.0 GPM [3.8 L] Pressure Compensating Female Spray Outlet
___ -16F	1.0 GPM [3.8 L] Vandal Resistant Pressure Compensating Female Spray Outlet
___ -17F*	1.5 GPM [5.7 L] Vandal Resistant Pressure Compensating Female Aerator
___ -18F*	1.5 GPM [5.7 L] Vandal Resistant Pressure Compensating Female Laminar Flow
___ -19F*	1.5 GPM [5.7 L] Anti-Microbial Pressure Compensating Female Laminar Flow Outlet
___ -21F	1.0 GPM [3.8L] Female Laminar Flow Outlet
___ -22F	1.0 GPM [3.8L] Vandal-Resistant Female Laminar Flow Outlet
___ -23F	1.5 GPM [5.7L] Pressure Compensating Female Aerator

ZURN INDUSTRIES, LLC. ♦ COMMERCIAL BRASS OPERATION ♦ 5900 ELWIN BUCHANAN DRIVE ♦ SANFORD NC 27330

Phone: 1-800-997-3876 ♦ Fax: 919-775-3541 ♦ World Wide Web: www.zurn.com

In Canada: ZURN INDUSTRIES LIMITED ♦ 7900 Goreway Drive Unit 10 ♦ Brampton, Ontario L6T5W6 ♦ Phone: 905-405-8272 Fax: 905-405-1292