



4" CENTERSET GOOSENECK METERING

Z866C0-XL

TAG _____



Engineering Specifications: Zurn AquaSpec® Z866C0-XL

Polished chrome-plated cast brass faucet body with integral shanks, slow-closing metering cartridges, 8" [203mm] centerline rigid or swing gooseneck spout, vandal-resistant color-coded metal handles. Easy adjustable cycle time, preset to 10 seconds at 80 PSI. Unit is furnished with a water-conserving aerator which reduces flow to .25 GPC [.95 L] (complying with ANSI A112.18.1 Standard for flow), mounting hardware, 1/2" NPSM coupling nuts for standard lavatory risers and integral shank filters.

Zurn Lead Compliant* "XL" products are a line of durable, high quality brass faucets and fixtures that are designed and manufactured to comply with state laws and local codes that mandate lead content levels. Zurn "XL" products are manufactured with *not more than 0.25% lead content when used with respect to wetted surfaces of pipes and pipe fittings, plumbing fitting and fixtures: California Health & Safety Code § 116875; Vermont 9 VCA § 2470h.

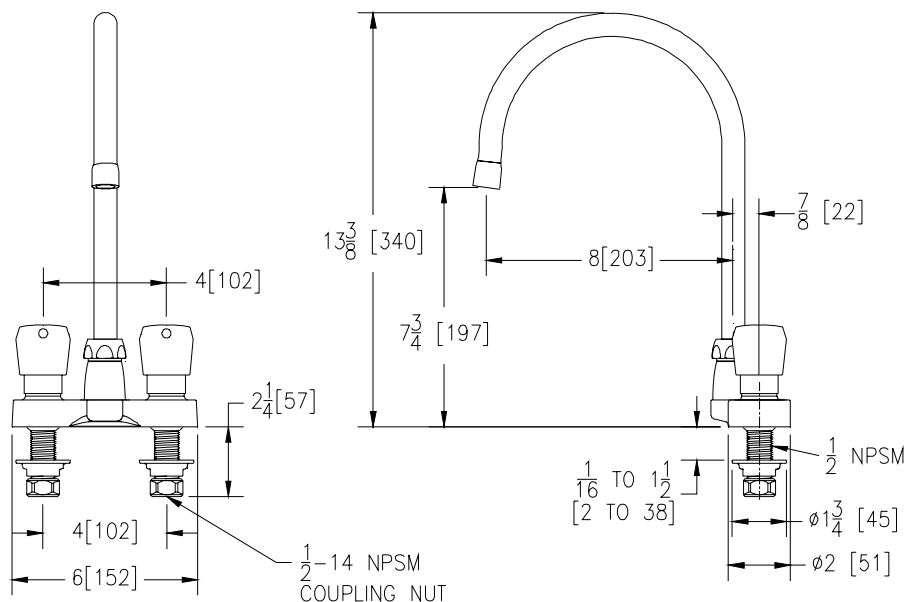

Note: All dimensions are for reference only. Do not use for pre-plumbing.

OPTIONAL ACCESSORIES

| Suffix | Description |
|----------|--|
| ___ -G | 1-1/4" [32mm] Grid Strainer Drain |
| ___ -GH | 1-1/4" [32mm] Offset Handicap Grid Drain |
| ___ -IN | Institutional Handle - Tamper-Proof and Vandal-Resistant |
| ___ -P | 1-1/4" [32mm] Pop-up Drain |
| ___ -PT | 1-1/4" [32mm] Cast Brass P-Trap with a 7-1/2" [191mm] Long 17-Gauge Wall Bend |
| ___ -RKR | ADA Compliant Rocker Handle |
| ___ -140 | 140° Restricted Swing Spout |
| ___ -3F | .5 GPM [1.9 L] Vandal-Resistant Pressure Compensating Female Spray Outlet |
| ___ -16F | 1.0 GPM [3.8 L] Vandal Resistant Pressure Compensating Female Spray Outlet |
| ___ -21F | 1.0 GPM [3.8L] Pressure Compensating Female Laminar Flow Outlet |
| ___ -22F | 1.0 GPM [3.8L] Pressure Compensating Vandal-Resistant Female Laminar Flow Outlet |
| ___ -24F | 0.35 GPM [1.3 L] Pressure Compensating Female Spray Outlet |
| ___ -25F | 0.35 GPM [1.3 L] Vandal-Resistant Pressure Compensating Female Spray Outlet |

ZURN INDUSTRIES, LLC ♦ COMMERCIAL BRASS OPERATION ♦ 2640 SOUTH WORK STREET ♦ FALCONER NY 14733

Phone: 1-800-997-3876 ♦ Fax: 1-919-775-3541 ♦ www.zurn.com

In Canada: ZURN INDUSTRIES LIMITED ♦ 3544 Nashua Drive ♦ Mississauga, Ontario L4V1L2 ♦ Phone: 905/405-8272 Fax: 905/405-1292