



Model F49BR / F49BRG

Fire Powerball Butterfly Valve

Application

Zurn Model F49BR / F49BRG Fire Powerball Butterfly sprinkler control valves provide for system shutoff to facilitate repair and maintenance. Fire Powerball Butterflies are operated with a slow closing 1/4 turn anti-water hammer valve. The valve should always be in the open position when the system is active. Tamper switches signal movement of the valve from the full open position to an alarm control panel, and to auxiliary equipment such as an indicating light or audible alarm in the area of the valve installation.

Standards Compliance

- UL® Listed
- C-UL®
- FM® Approved

Materials

Main body	Bronze ASTM 584 C83600
Disc	304 Stainless Steel
Handwheel	ASTM A216 WCB
Seat	ASTM D2000 Viton
Indicator	Powder Metal FD0205 95HT
Gearbox Housing and Cover	Brass ASTM B16 36000

Features

Sizes: 1", 1-1/4", 1-1/2", 2", 2 1/2"
 Maximum working water pressure 300 PSI
 Slow opening valve 1/4 turn anti-water hammer valve
 Sprinkler system deactivation tamper switches

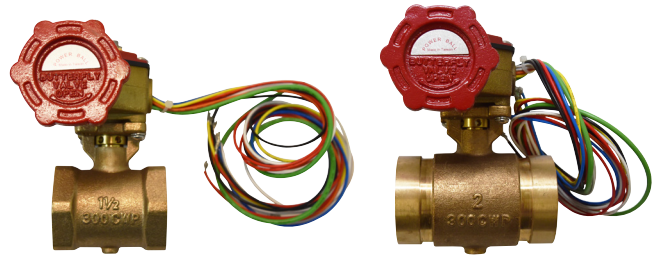

112-F49BR

2-F49BRG

Wiring

The tamper has two switches: Switch 1 has dual leads on the terminals for connection to the supervisory circuit of a listed system alarm control panel. Switch 2 has a single lead and is used for connection to auxiliary equipment.

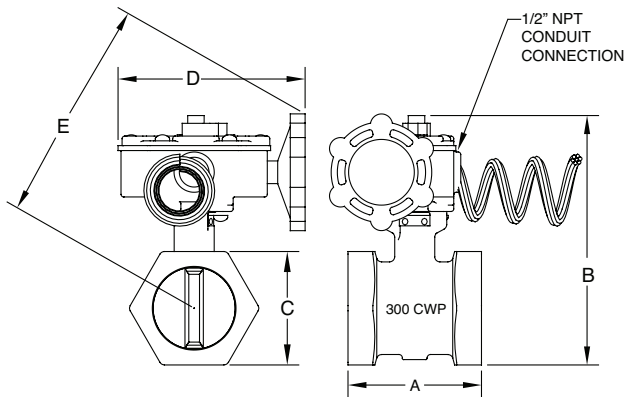

F49BR (THREADED ENDS)
 SIZE: 1", 1-1/4", 1-1/2", 2", 2-1/2"

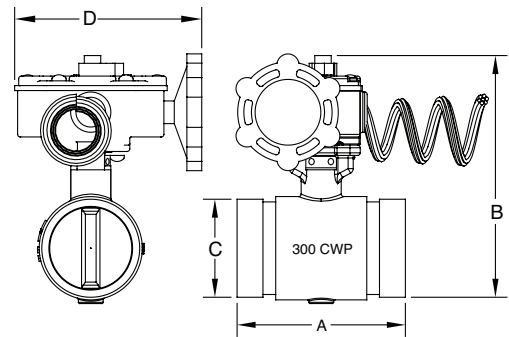

F49BRG (GROOVED ENDS)
 SIZE: 1-1/4", 1-1/2", 2", 2-1/2"

Dimensions & Weights (do not include pkg.)

MODEL	DIMENSIONS (approximate)											
	A		B		C		D		E		WEIGHT	
	in.	mm	in.	mm	in.	mm	in.	mm	Radius of Swing	Radius of Swing	lbs	kg
1-F49BR	2 1/8	54	4 1/4	107	1 5/8	40	4 5/8	118	5	127	3	1.4
114-F49BR	2 5/8	67	4 1/8	106	2	49	4 5/8	118	5	127	4	1.8
112-F49BR	2 7/8	73	4 3/4	121	2 3/4	70	4 5/8	118	5 1/4	133	4	1.8
2-F49BR	3 1/4	83	5	125	3 3/8	87	4 5/8	118	5 1/2	140	5	2.3
212-F49BR	4 1/2	114	5	125	3 3/8	87	4 5/8	118	6	152	7	3.2
114-F49BRG	3 7/8	98	4 3/8	111	1 5/8	42	4 5/8	118	n/a	n/a	4	1.8
112-F49BRG	4	102	4 1/2	114	2	48	4 5/8	118	n/a	n/a	4	1.8
2-F49BRG	4	104	4 7/8	122	2 3/8	60	4 5/8	118	n/a	n/a	5	2.3
212-F49BRG	4 1/2	114	5 1/4	132	2 7/8	73	4 5/8	118	n/a	n/a	6	2.7

Zurn Industries, LLC | Wilkins
 1747 Commerce Way, Paso Robles, CA U.S.A. 93446 Ph. 855-663-9876, Fax 805-238-5766
 In Canada | Zurn Industries Limited
 3544 Nashua Drive, Mississauga, Ontario L4V 1L2 Ph. 905-405-8272, Fax 905-405-1292

www.zurn.com

Rev. A
 Date: 10/18
 Document No. GV-F49BR
 Product No. Model F49BR

Installation Instructions

1. Installation must comply with NFPA 13 and NFPA 7
2. The valve can be installed in any orientation in a piping system with standard ASME B1.20.1 NPT or standard roll or cut grooved pipe.
3. When threading to pipe, apply adequate pipe sealants, use a wrench to clamp on the hexagon end of the valve.
4. The valves are intended for use with ANSI B36.10 Schedule 40 and/or Schedule 80 pipe, sizes 1", 1-1/4", 1-1/2", 2", and 2-1/2".
5. All unused wires must be capped with wire nuts and placed in a junction box.
6. A No. 14 green wire is fixed inside the switch housing as a ground.
7. All connections need to be reviewed and approved by the authority having jurisdiction.

Wiring Instructions

The tamper has two switches: Switch 1 has dual leads on the terminals for connection to the supervisory circuit of a listed system alarm control panel. Switch 2 has a single lead and is used for connection to auxiliary equipment. All unused wires must be capped with wire nuts and placed in a junction box. A No. 14 green wire is fixed inside the switch housing as a ground. All connections need to be reviewed and approved by the authority having jurisdiction.

WIRING DIAGRAM

SWITCH SHOWN POSITION WITH VALVE IN FULL OPEN

SWITCH 1 : DUAL LEADS SOLDERED TO SWITCH TABS

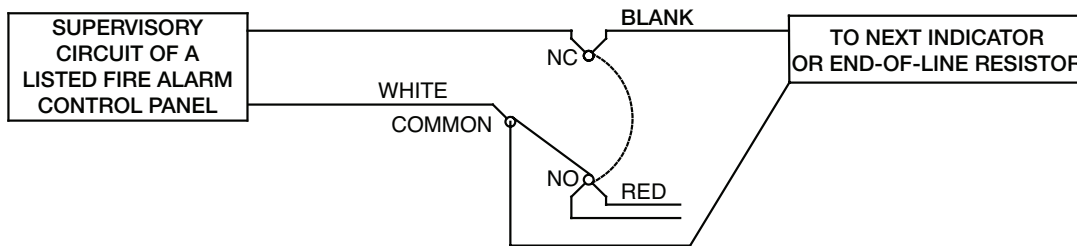

SWITCH 2 : SINGLE LEADS SOLDERED TO SWITCH TABS

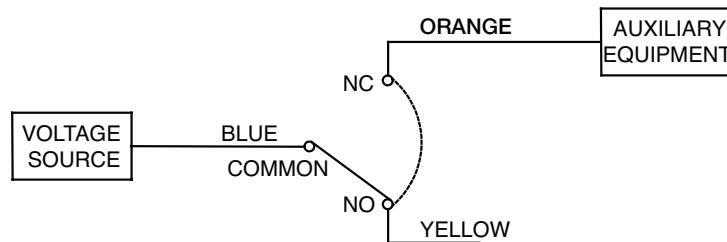

Green wire is provided as ground for the switch housing.
Switch rating: 10 Amps-115 VAC-60Hz, 0.5 Amps/28 VDC

