



# SMARTPRO G3 WIRELESS ALARM

## PRODUCT FEATURES & TECHNICAL SPECIFICATION

Design and Dimensional Data (inches and [ mm ]) are Subject to Manufacturing Tolerances and Change Without Notice

### Savings:

- Monitor provides real time data about grease and oil level sludge level, liquid level and even temperature inside the interceptor.
- E-mail, text, or cloud dashboard notifies when it is time to pump or when liquid level is too high, enabling on demand pumping.
- Eliminate the back breaking task of lifting cast iron covers to see inside of the interceptor.
- All data is available on cloud-based portal for real time information access and management.
- Long life lithium battery keeps system up and running.
- Transmits data via cellular frequency.

### Safety:

- Maintain total compliance and peace of mind by sharing data and pump out reporting with regulators.
- End to end data encryption.

### Stewardship:

- Accurate grease interceptor maintenance helps avoid catastrophic backups.
- High liquid level alarm informs of potential sewer backups.

### Style:

- Sensor mounts inside interceptor and communicates wirelessly with no external phone line or power requirements.
- Can be retrofit to most interceptor systems.
- Wireless communication via cell phone network.

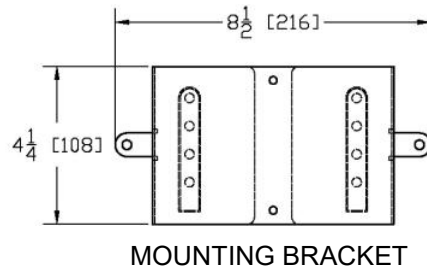
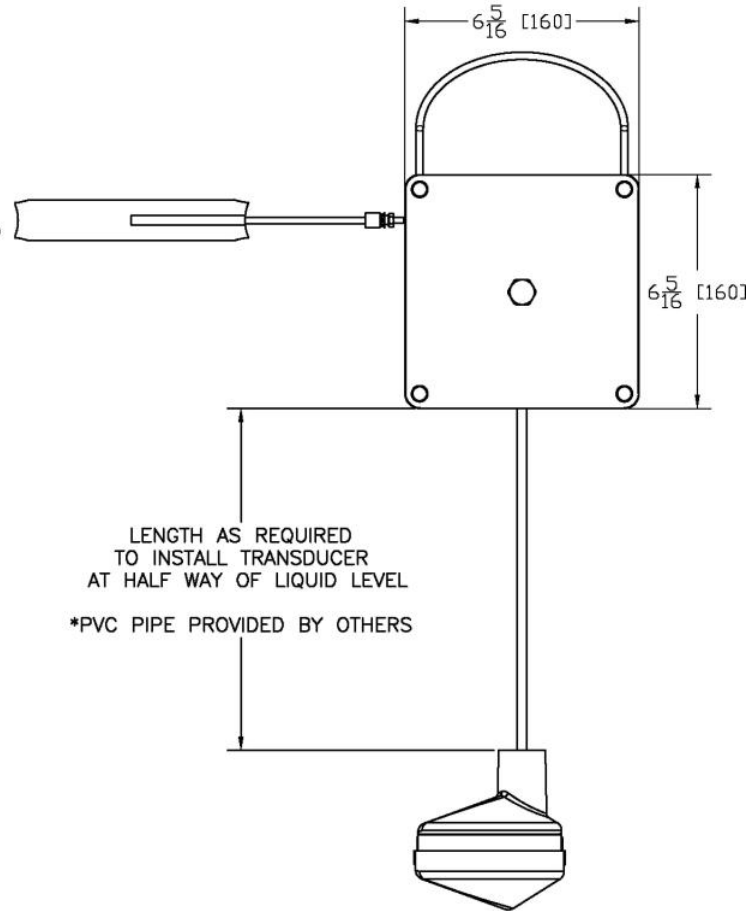

**⚠ WARNING:** Cancer and Reproductive Harm - [www.P65Warnings.ca.gov](http://www.P65Warnings.ca.gov)  
**⚠ ADVERTENCIA:** Cáncer y daño reproductivo - [www.P65Warnings.ca.gov](http://www.P65Warnings.ca.gov)  
**⚠ AVERTISSEMENT:** Cancer et effets néfastes sur la reproduction - [www.P65Warnings.ca.gov](http://www.P65Warnings.ca.gov)

Zurn Industries, LLC | Specification Drainage Operation  
 1801 Pittsburgh Avenue, Erie, PA 16502, Ph. 855.663.9876

In Canada | Zurn Industries Limited  
 7900 Goreway Drive, Unit 10, Brampton, Ontario L6T 5W6, Ph. 877.892.5216

[www.zurn.com](http://www.zurn.com)

Rev. -  
 Date: 07/10/23  
 C.N. No. 145375  
 Prod. | Dwg. No. SMARTPRO G3