



SMARTPRO G4 WIRELESS ALARM

PRODUCT FEATURES & TECHNICAL SPECIFICATION

Design and Dimensional Data (inches and [mm]) are Subject to Manufacturing Tolerances and Change Without Notice

Savings:

- Monitor provides real time data about grease and oil level, sludge level, liquid level, and even temperature inside the interceptor.
- Audio and visual alarm signals when it is time to pump enabling on demand pumping.
- Eliminate the back breaking task of lifting cast iron covers to see inside of the interceptor.
- Control panel can be mounted in facility manager's office or work area.
- Long life lithium battery keeps system up and running.
- Transmits data via radio frequency.



G4 CONTROL PANEL

Safety:

- Data can be shown to regulators on the control panel for total peace of mind compliance.
- End to end data encryption.

Stewardship:

- Accurate grease interceptor maintenance helps avoid catastrophic backups.

Style:

- Sensor mounts inside interceptor and communicates wirelessly (900 Mhz radio) to control panel plugged inside of building.
- Can be retrofit to most interceptor systems.
- Control panel can be connected to a Building Automation System for remote alarm notification.

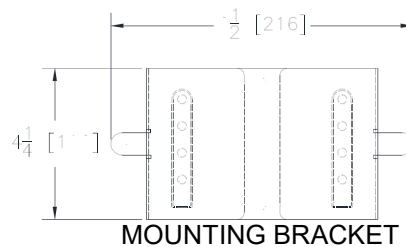
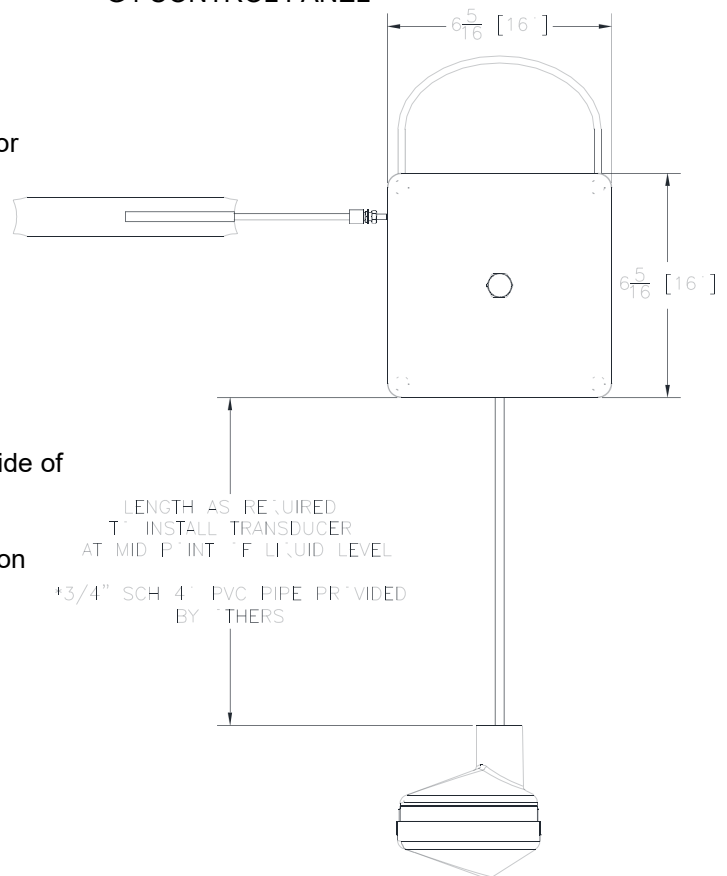

- ⚠ **WARNING:** Cancer and Reproductive Harm - www.P65Warnings.ca.gov
- ⚠ **ADVERTENCIA:** Cáncer y daño reproductivo - www.P65Warnings.ca.gov
- ⚠ **AVERTISSEMENT:** Cancer et effets néfastes sur la reproduction - www.P65Warnings.ca.gov

Zurn Industries, LLC | Specification Drainage Operation
1801 Pittsburgh Avenue, Erie, PA 16502, Ph. 855.663.9876

In Canada | Zurn Industries Limited
7900 Goreway Drive, Unit 10, Brampton, Ontario L6T 5W6, Ph. 877.892.5216

www.zurn.com

Rev. -
Date: 07/10/23
C.N. No. 145375
Prod. | Dwg. No. SMARTPRO G4