



Z1231EZ-WL

UNIVERSAL CONCEALED ARM CARRIER SYSTEM FOR WALL HUNG
LAVATORY W/ WASTE LINE SLEEVE

SPECIFICATION SHEET

TAG _____

Design and Dimensional Data (inches and [mm]) are Subject to Manufacturing Tolerances and Change Without Notice

PATENT
PENDING

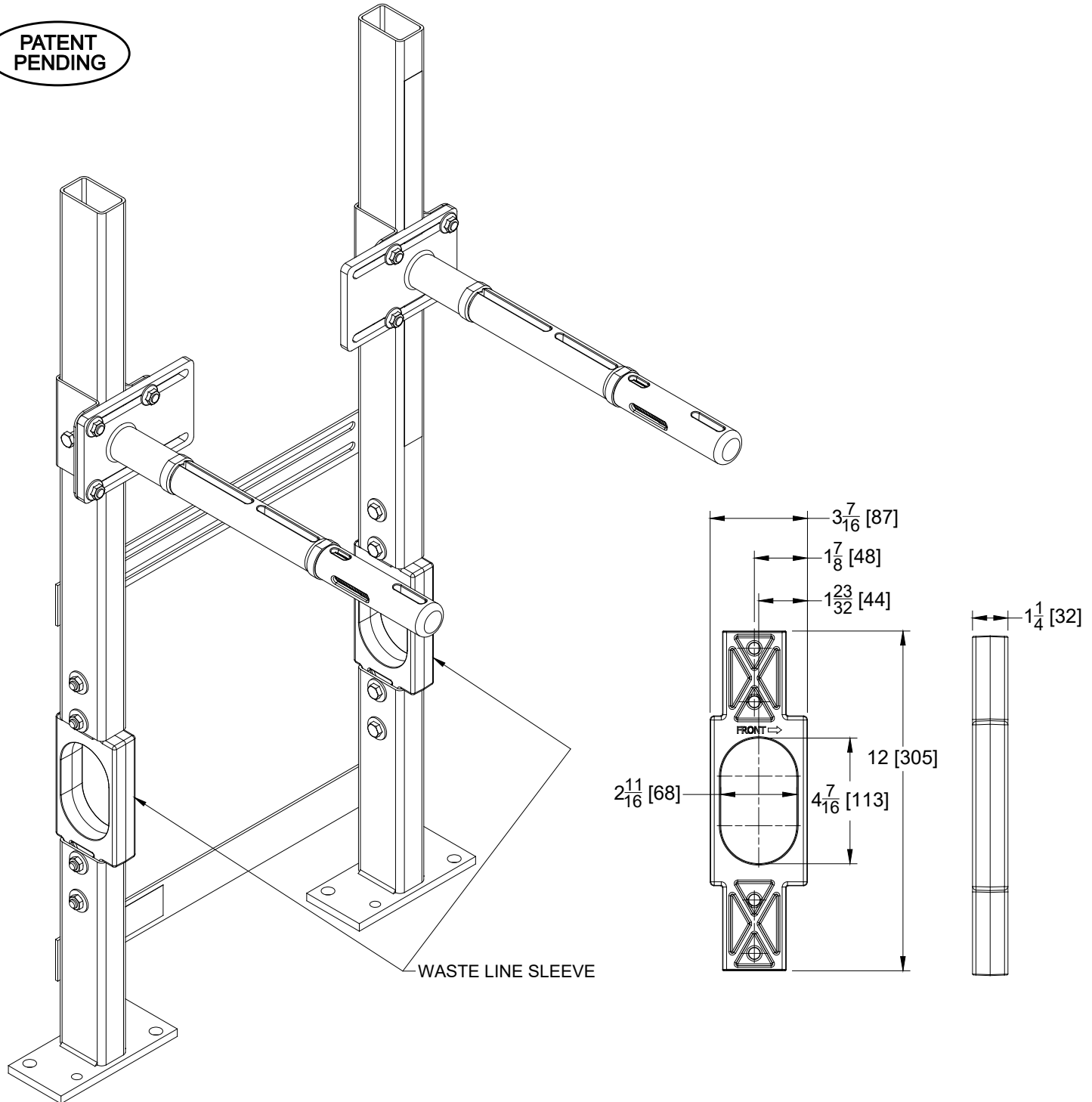

ENGINEERING SPECIFICATION: ZURN Z1231EZ-WL

Dura-Coated cast iron waste line sleeve designed for use with Z1231EZ Lavatory Carrier. Complete with integral positive stops for proper assembly with mating uprights and securing hardware. Sleeve allows for up to a 2 [51] waste line to pass through while meeting the strength and deflection criteria of the carrier system, as required by ASME A112.6.1M.

Zurn Industries, LLC | Specification Drainage Operation
1801 Pittsburgh Avenue, Erie, PA 16502, Ph. 855.663.9876

In Canada | Zurn Industries Limited
7900 Goreway Drive, Unit 10, Brampton, Ontario L6T 5W6, Ph. 877.892.5216

www.zurn.com

Rev. -
Date: 03/27/2020
C.N. No. 142524
Prod. | Dwg. No. Z1231EZ-WL