

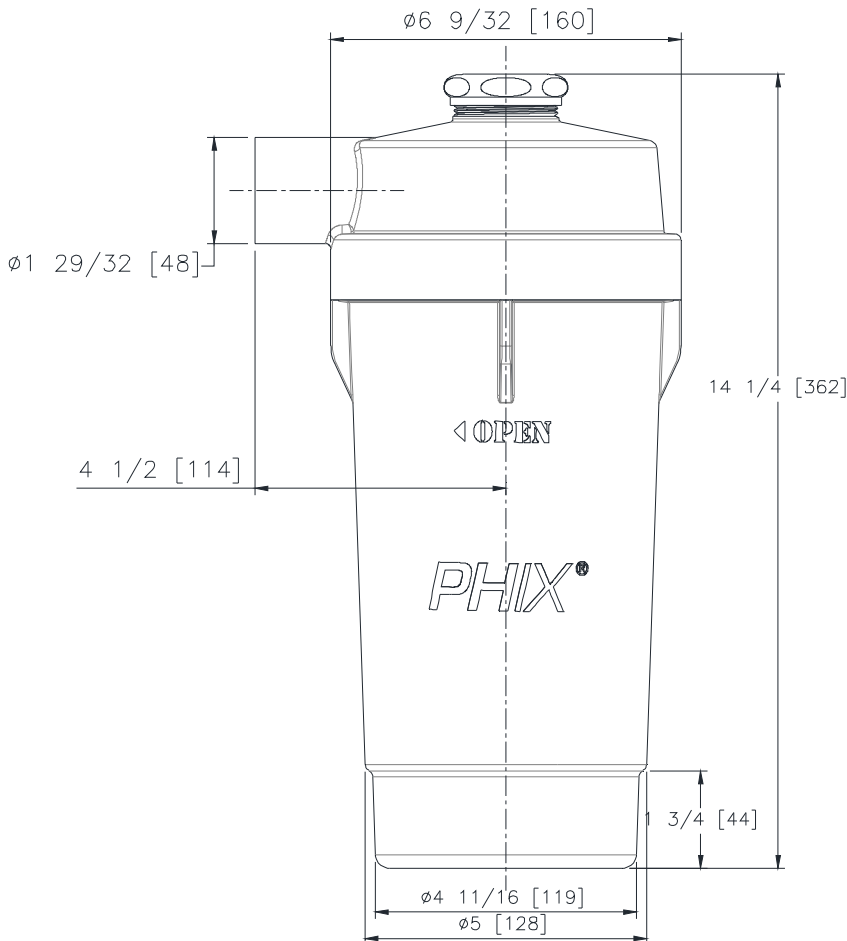

Dimensional Data (inches and [ mm ]) are Subject to Manufacturing Tolerances and Change Without Notice



**Engineering Specification: Z9A-PHIX**

Point of use application, replacing standard P-trap and the need for down stream acid waste piping. PHIX® Cartridge Acid Neutralization System includes industrial strength glass-filled polypropylene body with a 1-1/2" [38mm] compression fitting inlet and 1-1/2" [38mm] No-Hub outlet, removable upper neutralization chamber, and lower sediment collection chamber. PHIX® Cartridge has a maximum flow of 8 GPM [36 LPM]. System uses PHIX® Media, a mix of non-hazardous solid alkali non-resin materials to neutralize acids in a self-contained system.

**Suffix Options**

- \_\_\_ - MEDIA     Z9-PHIX-MEDIA-44 lbs (5 gal pail) Media Granules for Z9A-PHIX Tank
- \_\_\_ - FILTER    Z9-PHIX Dust Stop Washable Air Filter Disc